

PROPHON

SOUND SYSTEMS

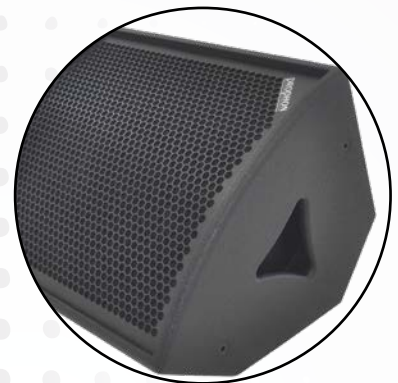

TRUST YOUR EARS !
MADE IN SWEDEN SINCE 1985

WHO WE ARE, AND WHAT WE DO...

Prophon Sound systems was founded in 1985 in Sweden, where we still design, develop, manufacture and assemble high-end sound systems for the professional market.

Our portfolio covers a wide range of models to meet the ever growing pursuit of the perfect sound. To make it easy we have divided all our models into comprehensive branches and series. Several speakers and systems can be used in several applications, so we have divided them into different categories,

- Tour

- Line array systems
- Hornloaded systems
- Point-source systems
- Cardioid subwoofers, front-loaded subwoofers
- Stage monitors

- Portable sound

- Portable sound systems,
- Point-source, hornloaded and line source speakers
- Multi purpose and fullrange speakers
- Stage monitors
- Subwoofers

- Fixed installations

- Passive fullrange speakers
- Column array speakers
- Line array speakers
- Front-loaded subwoofers
- Cardioid subwoofers

- Commercial audio

- Wallmounted speakers
- Ceiling speakers
- Subwoofers
- 19" rackmixers and zonemixers
- 19" mixer-amplifiers and zonemixer amplifiers
- 100V systems

- Electronics

- Amplifiers for installation, portable and tour
- DSP systems amplifiers for installation, portable and tour
- DSP loudspeaker manager systems processors for installation, portable and tour

- Cinema *(See separate catalogue)*

- Surround speakers,
- Screen speakers (2-way, 3-way and 4-way)
- CLAM (Cinema Line Array Module)
- Subwoofers
- Amplifiers and DSP amplifiers
- Processors and electronics

Our portable and tour systems are available in two versions:

- Active versions with built in amplifiers and DSP's,
- Passive versions with built in dedicated passive crossover networks, powered by any of our 19" DSP-systems amplifiers.

For the latest news, products, technical specifications, manuals, presets, downloads and catalogues please visit our website www.prophon.com

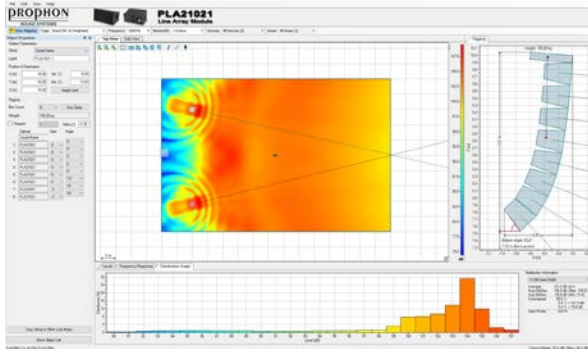

We use GLL files for simulation and calculations in EASE, for planning and projecting live performance, and installations, for a perfect result

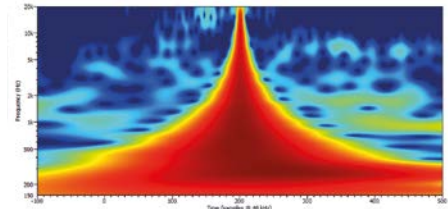

FIR filter coefficients available in our DSP's and system amplifiers for perfect phase, amplitude and delay alignment

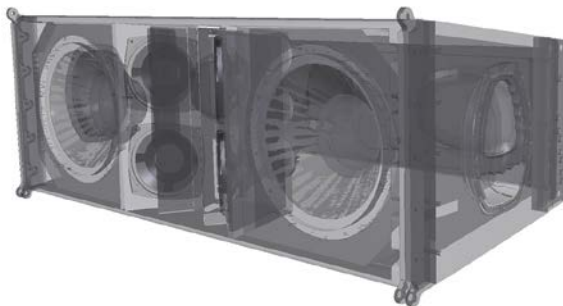

We use advanced 3D CAD software for development, design, pre-production and simulations. Testing hardware, horns, assembles and parts before productions



We measure and generate 3D files in acoustic anechoic chamber for importing into modelling and simulation softwares, such as EASE.

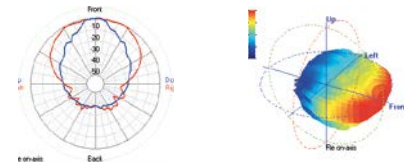

Design, assembly, manufacturing and development in our facilities in the north of Stockholm, Sweden, using only high quality components to ensure the very best result with reliable systems for a long lifespans.

APPENDIX

LOUDSPEAKERS TOUR, PORTABLE AND INSTALL

CLA-SERIES	PAGE 12	Column line array speakers for portable use, tour and fixed installations.
FX-SERIES	PAGE 13	Compact coaxial 2-way cube speakers for portable use, tour and fixed installations.
PX-SERIES	PAGE 14	High-power 2-way coaxial fullrange speakers for portable use, tour and fixed installations.
HX-SERIES	PAGE 15	3-way hornloaded fullrange speakers for portable use, tour and fixed installations.
CX-SERIES	PAGE 16	Multi purpose 2-way coaxial fullrange speakers and stage monitors for portable use and tour.
MX-SERIES	PAGE 17	Compact 2-way coaxial dedicated stage monitors for portable use, fixed installations and tour.
M-SERIES	PAGE 17	High-power compact stage monitor with built-in separate front-fill with adjustable aiming horizontal.
PLA-SERIES	PAGES 18-25	Line array speakers for tour and fixed installations, 2-way, 3-way, 4-way, cardioid, line array subwoofers.
HPX-SERIES	PAGE 26	Very high-power subwoofers for tour and high-profile fixed installations
HP-SERIES	PAGE 27	High-power subwoofers for tour and portable use.
HPC-SERIES	PAGE 28	High Power Cardioid subwoofers for tour, fixed installations and portable use.
CLUBLAND	PAGE 29	4-way hornloaded Club system for portable use, tour and fixed installations.
P-SERIES	PAGE 38	Economic active and passive systems, subwoofers, stage monitors and fullrange speakers PA-SERIES
PA-SERIES	PAGES 39-41	Active and passive portable sound systems with subwoofers and top speakers.
CA-SERIES	PAGE 42	Active and passive portable column array systems with column speakers and subwoofers.

LOUDSPEAKERS FIXED INSTALLATIONS

C.L.A.M	PAGE 30	Installation line array 2x10" / 4x1"- waveguide and horn, passive 8 ohm, 2-way, economic.
CS-SERIES	PAGE 31	Coaxial ceiling speakers, 2-way with 8 ohm and 100V taps for installation
PSC-SERIES	PAGE 31	High power pendant speakers, coaxial fullrange and subwoofer
VPX-SERIES	PAGE 32	Fullrange speakers 8"-15" for portable use and installation, active and passive versions.
VPS-SERIES	PAGE 33	Architectural 2-way fullrange wallmounted plastic installation speakers with 8 ohm and 100V taps
F-SERIES	PAGE 34	Fullrange point-source coaxial 2-way installation speakers
Pi-SERIES	PAGE 35	Economic fullrange point-source coaxial 2-way installation speakers
SL-SERIES	PAGE 36	Installation subwoofers from 8" to 21"
S-SERIES	PAGE 37	High-power Installation subwoofers from 12" to 2x21"

AMPLIFIERS, DSP's, PDU's, MIXERS, MIXER-AMPLIFIERS

V-SERIES	PAGE 43	High-Power 4-channel system amplifiers with DSP, FIR, loudspeaker database, touch-display.
P4DSP-SERIES	PAGE 44	4-channel DSP-amplifiers for tour, portable use and fixed installations.
D-SERIES	PAGE 45	4-channel high-power system installation amplifier with DSP, FIR, loudspeaker database touch-display
P-SERIES	PAGE 46	Amplifiers with/without DSP, 4, 6 and 8 channels for portable use, tour and fixed installations.
DSP-SERIES	PAGES 47-48	System DSP processors.
PDU-SERIES	PAGE 49	PDU (Power Distribution Units) from 16A to 32A for tour and fixed installations
PMA-SERIES	PAGE 50	Mixer amplifiers, zone mixers, zone matrix mixer amplifiers, 100V amplifiers for commercial installations
PM-SERIES	PAGE 51	Rackmixers, zone mixers, zone matrix mixers for commercial installations
AMPRACK	PAGE 52	Panels, cases and racks for tour, portable use and installation
HARDWARES	PAGE 53-54	Flying frames for line array, installation-brackets, hardwares, flywares, mounting equipment
NOTES	PAGE 55	Notes



TRUST YOUR EARS!
SOUND SYSTEMS
MADE IN SWEDEN
SINCE 1985





CLA-SERIES

COLUMN LINE ARRAY FOR ARCHITECTURAL INSTALLATIONS, LIVE PERFORMANCE, SPEECH, AND FOR PORTABLE USE WITH SUBWOOFERS.

With line source coupling for a low loss of energy over distance, long throw, a controlled narrow vertical dispersion pattern and a wide horizontal dispersion, the CLA-series is designed for installation in churches, auditoriums, conference facilities, theatres and other venues where low distortion, clarity, control and longthrow is important.

The CLA-series in combination with the S-series or B-series LF subwoofers will transform the CLA-series into a powerful sound system, for live performance, installations or recorded music reproduction.

PAGE 12



FX-SERIES

POINT-SOURCE 2-WAY COAXIAL FULLRANGE SPEAKERS.

The F-series features three models from 6,5" to 10" of fullrange speakers designed for High power reinforcement systems.

With coaxial design for optimum phase coherency and true point-source behaviour.

Designed for installation in theatres, live performance venues, churches, conference centers, nightclubs, theme-parks, cruise ships and for portable use with subwoofers.

PAGE 13

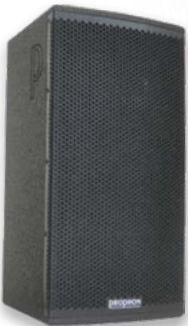

PX-SERIES

2-WAY POINT-SOURCE HIGH-POWER FULLRANGE SPEAKERS FOR TOUR, INSTALLATION AND PORTABLE USE

The PX-series is a range of 2-way compact high-SPL fullrange speakers, ranging from the smallest PX26 with 2x6,5"/1", to the largest PX210 with 2x10"/1,3".

Designed for portable use with subwoofers in compact high-power sound system, fixed installations, delay system in larger venues, and stand alone fullrange.

PAGE 14



HX-SERIES

3-WAY HORNLOADED POINT-SOURCE FULLRANGE SPEAKERS WITH DIPOLE C.C.C. TECHNOLOGY, FOR HIGH POWER INSTALLATIONS, PORTABLE USE AND TOUR.

The best of three worlds combined into one loudspeaker series!

The HX-series combines hornloaded technology, with point-source and dipole C.C.C.

(Common Compression Chambers)

Two models are available; HX8 and HX10, with hornloaded midrange for long throw, low distortion levels, controlled dispersion pattern and high sensitivity for unparalleled reproduction of vocals and acoustic instruments, with 2 x LF woofers mounted in a dipole C.C.C configuration for high sensitivity, long throw and minimum transducers excursion, handling low frequency reproduction down to 50Hz with ease.

HF frequencies features a 1" driver with 1,7" voice coil mounted on an asymmetric ellipsoid waveguide.

Both models are available in active and passive versions.

PAGE 15



CXL-SERIES

2-WAY POINT-SOURCE COAXIAL MULTI PURPOSE SPEAKERS FOR PORTABLE USE, TOUR, PA AND INSTALLATION

The CXL-series is a favorite with the rental, PA and event industry because of the versatility they offer, the CXL-speakers can be used as high power stage monitors, top speakers in small to medium FOH PA-systems with subwoofers, sidefill, frontfill, delay system in larger PA-systems and in installations. The series features four models from 8"/1" to 15"/2"

All models except the CX81 is available as active, with built in amplifiers with DSP and presets.

PAGE 16



MX-SERIES AND M103F FRONT-FILL HYBRID STAGEMONITOR

MX-SERIES: COMPACT 2-WAY HIGH POWER COAXIAL STAGE MONITORS WITH SMALL FOOTPRINT AND LOW LISTENING ANGLE

M103F: UNIQUE, COMPACT POWERFUL STAGEMONITOR WITH BUILT-IN FRONT-FILL

MX-series designed for small stages, auditoriums, conference centers, ensembles and tv studios. With a small footprint and low height, the MX-series is ideal for monitor listening where space is limited and the stage monitor is close to the user. The dispersion angle allows for standing or sitting close to the monitor and still retain on-axis fullrange frequency response.

M103F hybrid stagemonitor / front-fill, with two separate coaxial speakers, one for stage monitor, and one for front-fill, with separate input, connectors under the speaker for discrete cabling, M103F for a clutter-free stage with no need for additional external front-fill speakers all over the stage, front-fill adjustable horizontally

PAGE 17

PLA-SERIES

PROPHON LINE ARRAY, FIVE DIFFERENT MODELS OF LINE ARRAY SYSTEMS DESIGNED FOR LIVE PERFORMANCE, FESTIVALS, TOUR, FIXED INSTALLATION AND THE RENTAL INDUSTRY.

The PLA-series features five different line array modules, from the most compact PLA621 with 1 x 6,5" / 2 x 0,75" components, to the largest PLA212 with 2 x 12" / 4x6,5" / 3x1" The series is designed for small to large sized venues, installations and events. All models in the series utilizes the same technology to achieve the control, dispersion, sensitivity and high SPL they are renowned for. Specially designed waveguides, soundguides and dipolar configuration in combination with 20 years experience of line array design and customer feedback is what makes our line array systems so special.

The PLA-series can be used from small compact portable groundstacked systems with subwoofers, up to full scale line array system in large festivals.

PAGES 18-25

HPX-SERIES

HIGH POWER SUBWOOFERS FOR TOUR AND FIXED INSTALLATION, SEVERAL MODELS AND SIZES FOR A VARIETY OF APPLICATIONS.

Our HPX-series, direct radiating front-loaded tuned bassreflex subwoofers all features a special heavily braced cabinet construction for minimum loss in energy, all models can be used either as single ended or stacked in cardioid configuration or in end-fire array.

All presets are available in our systems loudspeaker DSP and in our DSP-systems amplifiers.

All subwoofers in the HPX-series features hardwares, top hat and fly-points for rigging, installing and for stacking, groundstacking and for portable systems.

PAGE 26

HP-SERIES

HIGH POWER SUBWOOFERS FOR INSTALLATION, PORTABLE, RENTAL AND EVENT, SEVERAL MODELS AND SIZES FOR A VARIETY OF APPLICATIONS.

Our HP-series, direct radiating front-loaded, single driver, vented port subwoofers all features a special heavy braced cabinet construction for minimum loss in energy, all models can be used either as single ended or stacked in cardioid configuration or in end-fire array. All presets are available in our systems loudspeaker DSP and in our DSP-systems amplifiers.

The active versions features two amplifiers, where one drives the internal woofer, and one is assigned to a Neutrik Speakon out, with several presets for external subwoofers or top speaker, so that the woofers in the HP-series can act like a master for driving an additional passive subwoofer, or supply any of our portable passive fullrange speakers in a compact active sound systems.

PAGE 27

HPC-SERIES

HIGH POWER CARDIOID SUBWOOFERS FOR TOUR, INSTALLATION, PORTABLE USE, RENTAL AND EVENT,

The flagship when it comes to low frequency emission and control, the HPC-series offers out-of-the-box cardioid configuration with drivers both in the front and in the back in a cardioid configuration.

Whether using in fixed installations or for tour applications the HPC-series is liked by DJ's, sound engineers, musicians, event companies and rental companies because of the many benefits with the cardioid technology, where the low frequencies are cancelled out behind and on the sides of the subwoofers, using that energy forwards, adding several dB in SPL on axis.

PAGE 28

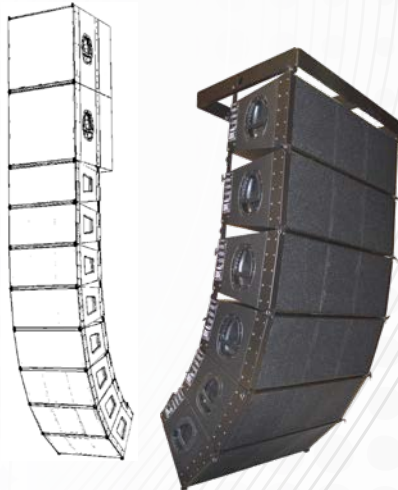



CLUBLAND SYSTEM

4-WAY, HORNLOADED POINT-SOURCE GOUNDSTACKED OR FLEWN CLUB SYSTEM FOR LARGE VENUES, NIGHTCLUBS AND LIVE PERFORMANCE FOH.

The clubland system was developed for the club-scene, designed for high-profile nightclubs. with very high SPL capabilities, high sensitivity, controled dispersion pattern, extreme powerhandling and long throw. The system can be ordered with horns, grilles and hardwares in any RAL color for blending with the interour of the venue. Two different MF/HF hornloaded modules are available, with 8"1" or with 12"1/2", furthermore the LF-module features two 15" woofers mounted in a compact dipol C.C.C. (Comon Compression Chamber) configuration. There are a number of suwoofers to chose from depending on need and demand, from our 2x12" hornloaded behemoth, to standard 18" direct radiating vented subwoofers, and cardioid 3x18" subwoofers.

The Clubland system is also designed to be used as a high power PA system in live performance stages, using the live-presets instead of the club presets in the DSP.

PAGE 29



C.L.A.M

Column Line Array Speaker for fixed installations

The CLAM line array module is a line array module designed for fixed installations in a variety of applications, due to cabinet and hardwares designed for fixed installations instead of versatile tour applications, the CLAM module has a significantly lower price compared to similar line array systems designed for touring.

We have also essentially packed two medium sized line array modules into one cabinet saving space and cutting cost even more. The CLAM system is very shallow to allow for discrete installations where depth is an issue.

PAGE 30



CS-SERIES & PSC-SERIES

Ceiling, in-wall speakers & pendant speakers

The CS-series, ceiling speakers and PSC-series pendant speakers, are used for installation in commercial audio and fixed installations, in restaurants, shops, malls, office, leisure and entertainment, industry. several models and sizes, with Lo-Z 8 ohm and Hi-Z 100V with different power-taps. available in white and black, 2-way coaxial design for full frequency responce, Subwoofers are also a part of the series

PAGE 31



VPX-SERIES

Fullrange speakers for portable use and installations

The perfect allround-speaker, available passive 8 ohm, and active with built-in class-D amplifiers with DSP, several presets, custom EQ and delay, with several modes such as fullrange, HP-filter and monitor. VPX-series is manufactured in a special plastic and painted with exterior speaker paint for withstanding tour and on-the road handling.

PAGE 32



VPS-SERIES

Wall mounted weather-resistant architectural installation speakers

The VPS range of fullrange two-way speakers encompasses four sizes of two-way fullrange speakers for installation in a variety of applications, with Lo-Z 8 ohm input and select switch for Hi-Z 100V input with several different power taps, the VPS series is a versatile range of speakers for architectural installations.

PAGE 33



F-SERIES

Fullrange installation speakers

The F-series is a range of two-way point-source fullrange speakers for use in fixed installations in most applications, Coaxial design permits for uniform directivity with controled and coherent frequency responce.

PAGE 34



Pi-SERIES

Fullrange installation speakers

The Pi-series is a range of two-way point-source fullrange speakers for use in fixed installations in most applications, with the same horn in each speakers in the series, very good timbre matching is achieved with the same dispersion and frequency response in the HF frequencies, allowing for different models in the series to be installed without timbre matching issues.

PAGE 35



SL-SERIES & S-SERIES

HIGH POWER SUBWOOFERS FOR INSTALLATION

Our S-series, direct radiating front-loaded, tuned vented port subwoofers all features a special heavy braced cabinet construction for minimum loss in energy, from the smallest 8" subwoofer, to the massive 2x21" subwoofer. All presets are available in our systems loudspeaker DSP and in our DSP-systems amplifiers. SL series features slightly lower power handling compared to the S-series

PAGE 36-37



P-SERIES

AFFORDABLE ACTIVE AND PASSIVE PORTABLE SYSTEMS, SUBWOOFERS, STAGE MONITORS AND FULLRANGE SPEAKERS, FOR BANDS, DJ'S AND FIXED INSTALLATIONS.

Designed for portable use, event, bands and DJ's, the K-series is an affordable range of subwoofers, fullrange speakers and sound systems, available active with built-in amplifiers and DSP's, and passive with external 19" systems amplifiers.

The K-series is perfect for installing in schools, small nightclubs, lounges, bars and live stages. several M10 lifting points for easy installation, with an abundance of rigging and installation hardware available.

PAGE 38



PA-SERIES

ACTIVE AND PASSIVE PORTABLE POINT-SOURCE SYSTEMS WITH SUBWOOFERS AND TOP SPEAKERS, FROM 12" SUBWOOFER AND 6,5"/1" TOP, TO 2X18" SUBWOOFERS AND 15"/2" TOP

Designed for portable use, the rental industry, event, bands, DJ's and fixed installations, The PA-series is a comprehensive range of complete sound systems developed to reproduce live music as well as recorded music and club music.

With several presets in each active speaker depending on application.

High-end class-D amplifiers for best performance with reliable systems that just keeps delivering, night after night. The active systems features built-in amplifiers and DSP's, the passive systems features external 19" DSP-systems amplifiers.

PAGES 39-41



CA-SERIES

ACTIVE AND PASSIVE COLUMN ARRAY SYSTEMS WITH LINE SOURCE TECHNOLOGY AND DIRECT RADIATING SUBWOOFERS.

The series was designed for portable use and installation, where a powerful, but yet discrete system is asked for, the line source column array speakers has a controlled vertical and horizontal dispersion pattern, with a -3dB loss for each doubling of distance, instead of -6dB as in regular speakers, this ensures long throw, and a even SPL in the listening area.

there are eight different systems and configurations, with 12", 15" and 18" subwoofers in combination with the CLA835 (8x3,5") column array and the CLA4611 (4x6,5"/1") column array.

PAGE 42

AMPLIFIERS - SYSTEMS AMPLIFIERS

For tour, installation and portable use we offer our range of systems amplifiers, 19" amplifiers 1RU and 2RU (depending on power, series and number of channels) The flagship V-series features built-in high-end DSP's with loudspeaker database where all our speakers are stored with FIR coefficients for optimum phase coherency. The user can build, manage and store their own systems and setups using the loudspeakers in the database. There are an abundance of features for system integration and system tuning, such as IIR EQ, crossover, delay, limiter, matrix function, all amplifier features (Power Factor Correction) wide voltage input (90-250V) with switched mode power supplies. Presets are the same whether you use active speakers with built-in amplifiers, or if you prefer passive speakers with the external 19" DSP systems-amplifier.

PAGE 43-46



DSP SERIES - DSP PROCESSORS

We offer DSP processors with loudspeaker database housing all Prophon speakers. Designed for when you want to use regular amplifiers without built-in DSP's, or if you want to use existing amplifiers in an installation but upgrade the sound system to Prophon, or if you prefer the amplifiers you have in your stock and want to use Prophon speakers with them.

PAGE 47-48



PDU-SERIES - POWER DISTRIBUTION UNITS

We have several PDU's, from 16A, to 32A and 63A, designed for tour and fixed installations, with or without meters, with grouped MCB, RCB, RCBO, for safe and logic work-flow. All PDU's was designed in collaboration with leading rental and installation companies.

PAGE 49



PMA-SERIES - MIXER-AMPLIFIERS AND ZONEMIXER-AMPLIFIERS

In a lot of commercial audio installations a centralized multifunction machine is the simplest and best solution, we offer a range of commercial audio amplifiers, mixer amplifiers, zone mixer amplifiers and zone matrix mixer amplifiers, from one channel and one zone, up to 6 zones with local networked wall-panels and total freedom in signal distribution.

PAGE 50



PM-SERIES - ZONE MIXERS AND ZONE MATRIX MIXERS

We offer a complete range of commercial audio mixers, zone mixers and zone matrix mixers for installation in most environments and applications, from small single zone installations with a couple of sources, to large multi zone systems with signal matrix for source and zone distribution.

PAGE 51



PRO-AMP RACKS

For tour and large format installation we offer our PRO-AMP RACKS. Pre-assembled racks or cases with PDU (Power Distribution Unit) Connector panel and DSP-amplifiers, mounted and wired for "out-of-the-box" use. We supply several different AMP-RACKS, from small 1-phase 16A, to 3x16A, 32A and 63A. All PDU's features meters, RCD, RCB with daisychained networking.

We offer a variety of connectors, depending on what is standard in your region, from Neutrik Speakon 4-pol and 8 pole, to multipin connectors, 8, 16 and 19 PIN. All amp-racks are ordered as custom products due to the large variety of applications and needs.

PAGE 52



AMPRACK PANELS

Our amprack panels for tour was designed for comprehensive cabling and connectivity, with all connectors, line, ethernet, speaker and software easily accessible on the front panel, the smallest AMPRACK 01, supports one 4-channel amplifier and 16A power input in 1RU, the AMPRACK02 supports up to 4 x 4 channels.

PAGE 52

HARDWARE, FLYWARE AND INSTALLATION EQUIPMENT

We design and manufacture hardwares to make your life easy

PAGE 53-54

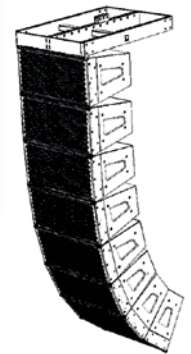
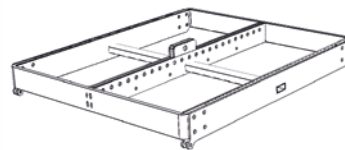
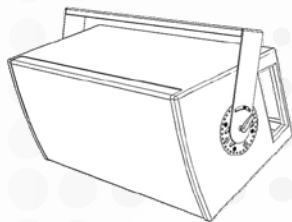
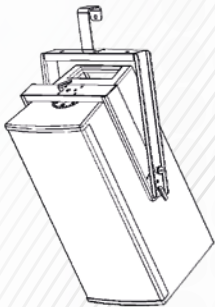

ACTIVE OR PASSIVE?

WHY CHOSE? WE HAVE IT ALL!

As a Prophon-user, we have made it easy for you to use, configure and setup the system that suits your needs. Most speakers are available in two versions:

- 1) Active versions, with built in amplifiers and on-board DSP with several presets
- 2) Passive versions with built-in passive crossover network, using external 19" systems DSP-amplifiers or processors

We supply the same presets no matter if you like active speakers or passive, so the sound remains the same.

Usually installation is made with passive speakers and external 19" DSP systems amplifiers.

Tour systems are also mostly passive speakers with AMP-racks.

Regarding portable systems, about half of the users favours active systems, and half of the users want to use passive systems, we make the choice easy by supplying the best of two worlds.



ACTIVE SYSTEMS WITH BUILT-IN AMPLIFIERS AND DSP's

Our portable active sound systems, fullrange speakers, stage monitors and subwoofers all features built-in class-D amplifiers with PFC (Power Factor Correction) wide mains voltage input (90-250VAC) with switched mode, light weight, power supplies.

We use Powersoft amplifier modules for best quality, reliability and stability.

Each module also features high-end on-board DSP processing, with several presets in each speaker for a variety setups and uses.

Our latest HPX subwoofers features 3,2kW RMS power for each woofer, delivering an astounding SPL. Presets are the same whether you use active speakers with built-in amplifiers, or if you prefer passive speakers with external 19" DSP systems-amplifier or the systems DSP processor, so that you can mix active and passive speakers without losing timbre matching.

CLA-SERIES

Line source column array for installation, event and portable use

INTRODUCTION

The CLA-series was designed for reproducing speech, vocals, music and live instruments, with a controlled dispersion pattern vertical, wide dispersion pattern horizontal, long throw and full frequency response.

The CLA835 is available passive, the CLA4611 is available both active, with built in 700W DSP-controlled amplifiers, and passive, with 8 ohm impedance.

The CLA835 array speakers can also be used in powerful, compact, active or passive sound systems with the B11, single 12" direct radiating tuned bassreflex subwoofer, for portable use and installation, where the active system features 1000W + 2 x 500W DSP controlled amplifiers housed in one of the B11 subwoofer, with several presets depending on setup and application.

The CLA4611 can be used with the B18HP or the B1HP. active or passive subwoofers for powerful sound systems in installations or for portable use, where the active versions features 2500W + 2 x 800W DSP-controlled amplifiers. with several presets (see separate section under AC-SERIES)

FEATURES

- Three models available:
 - CLA435
 - CLA835 featuring 4 x 3,5" neodymium transducers
 - CLA4611 featuring 4 x 6,5" neodymium transducers and a coaxially mounted 1" driver on horn
- True line source coupling with a -3dB loss in SPL for each doubling of distance
- Wide dispersion pattern horizontal / Controlled narrow dispersion vertical
- Long throw
- Full frequency response
- Designed for installation in theatres, conference centers, churches, live performance
- Designed for portable use with subwoofers in active or passive systems.
- Extensive rigging and installation hardwares available
- Compact format large sound
- Narrow width allows for architecturally challenging installations and events.

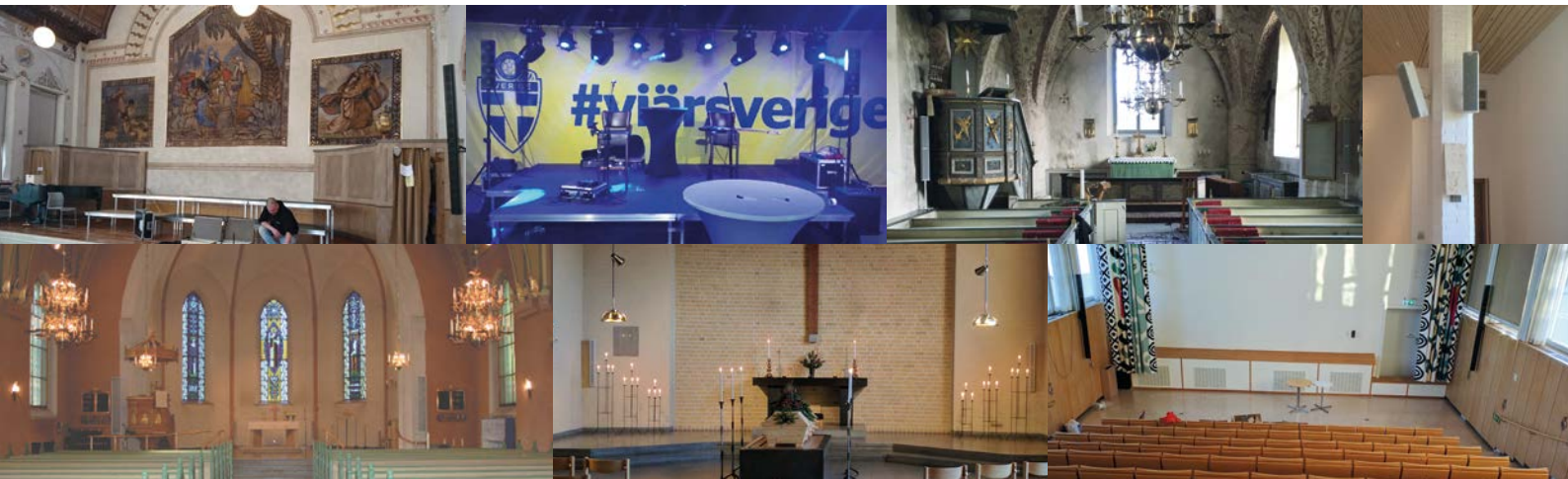

CLA-series in portable active or passive sound systems with subwoofers



MODEL	CLA435	CLA835	CLA4611	CLA4611A
Design	fullrange column array line source	fullrange column array line source	2-way passive column line source	2-way active column line source
Components	4 x 3,5" Neodymium	8 x 3,5" Neodymium	4x6,5"/1" coax	4x6,5"/1" coax
Power Handling cont.	360W	720W	1300W	1300W
Frequency response	110Hz - 17kHz	110Hz - 17kHz	60Hz + 19kHz	60Hz - 19kHz
Sensitivity	1Pi: 94dB 2Pi: 97dB	1Pi: 97dB 2Pi: 100dB	1Pi: 100dB 2Pi: 103dB	1Pi: 100dB 2Pi: 103dB
Max SPL (calc peak 2Pi)	127 dB	130 dB	135dB	136dB
Nominal Impedance	16 ohm	8 ohm	8 ohm	8 ohm
Dispersion	H120 x V20	H120 x V20	H110 x V30	H110 x V30
Dimensions	H475x110x110	H945x110x110	H680xW170xD170	H680xW170xD170
Weight	2,75kg.	5kg.	10,5 kg	13 kg
Amplifier channels	1	1	1	1
Additional information active version	-	-	-	1200W class-D amplifier with DSP
Hardware	Installation bracket, external top hat, Hook for truss, quick-connect hardware for connecting several speakers.quick-rigging for installation and portable use			

FX-SERIES

Compact coaxial high-power 2-way point-source fullrange speakers for portable use and installation



INTRODUCTION

The FX-series 2-way coaxial passive point-source fullrange speakers was designed for fixed installations in a wide variety of facilities for a wide variety of applications, such as restaurants, nightclubs, conference centres, bars, theatres, cruise ships, theme parks and other facilities where design, size and quality is in focus.

The FX "cube" series is appealing in design with a clean and discrete look with integrated hardware for installing and rigging.

Neodymium coaxial transducers results in light weight and high SPL.

Furthermore, the FX-series can also be used for portable applications, using the external 35 mm. top hat with the adjustable bracket, either stand-alone as front-fill or delay, or with subwoofers in compact portable sound systems.

FEATURES

- Three different sizes from 6,5"/1" to 10"/1,4"
- 2-way coaxial point-source design
- Passive
- Adjustable installation bracket with fixed 5 degree aiming points set with release pins
- Coaxial design for best linear point-source performance
- A variety of input connectors, Neutrik Speakon NL4, Phoenix, Push terminal
- Integrated hardware for bracket, external 35 mm. top hat, mounting on stand, clamps
- Can be used with active subwoofers in a portable sound system
- Can be ordered in any RAL colour or white upon request.

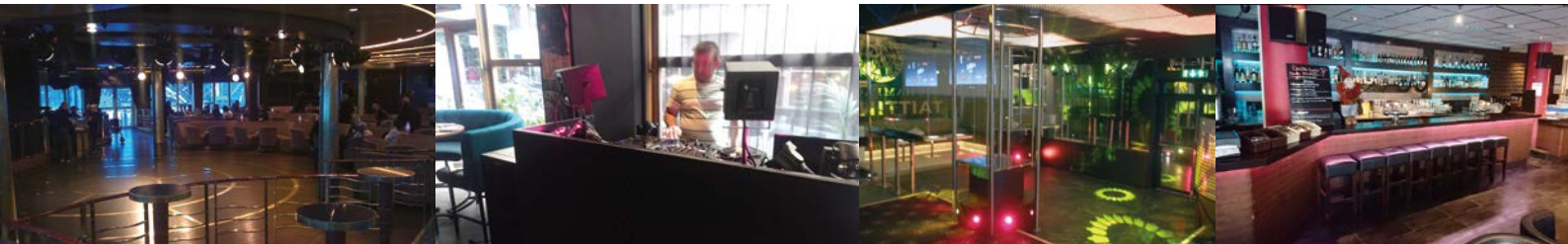

MODEL	F6X	F8X	F10X
Design	Front-loaded, tuned point-source coaxial	Front-loaded, tuned point-source coaxial	Front-loaded, tuned point-source coaxial
Components	LF: 6,5" with 2" voice coil HF: 1" with 1,4" voice coil	LF: 8" with 2" voice coil HF: 1" with 1,7" voice coil	LF: 10" with 2,5" voice coil HF: 1,4" with 2,5" voice coil
Power Handling	300W cont. 150W RMS	500W cont. 250W RMS	500W cont. 250W RMS
Frequency response	90Hz - 18kHz	70Hz - 18kHz	60Hz - 18kHz
Sensitivity	92dB open space 95dB 2Pi	97 dB open space 100 dB 2Pi	97dB open air 100dB 2Pi
Max SPL (calc. peak)	123dB	130 dB	130 dB
Nominal Impedance	8 ohm	8 ohm	8 ohm
Dispersion	70 x 70	100 x 100	70 x 70
Dimensions	190 x 190 x 190	240 x 240 x 240	300 x 300 x 300
Weight kg.	5	8	10
Amplifier channels	1	1	1
Active version	No	No	No
Hardware	Bracket, external top hat, clamp for truss	Bracket, external top hat, clamp for truss	Bracket, external top hat, clamp for truss



NANO
compact active portable sound system with F6X and active B11 sub with 1000W + 2 x 500W dsp-controlled amplifiers.

PX-SERIES

2-way point-source, compact fullrange speakers

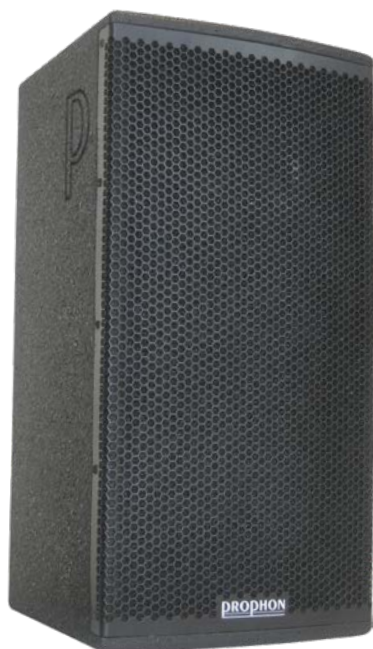

INTRODUCTION

The PX-series 2-way point-source high-power coaxial fullrange speakers was designed for portable use, fixed installations and events in a wide variety of applications. Very compact format and light weight in regards to max SPL output, the PX-series is ideal for small to medium sized live performance and club-events with any of the subwoofers in the HP, HPX or HPC- series in compact high-power portable sound systems.

PX-series is available as either active versions with built-in 1200W amplifiers and DSP with several presets, or passive with external 19" DSP-systems amplifier. Due to the fact that the dispersion pattern of the horns are conical, installation of the PX-series horizontal using the installation bracket results in installation speakers with very low height, suitable for high-power architectural installations or where height is limited.

FEATURES

- Three different sizes from 2x8"/1" to 2x12"/2"
- 2-way coaxial point-source design
- Two handles discreet in the back
- Special hardware mounted on two sides for quick-rigging hardware.
- Two direct radiating front-loaded transducers for optimal phase coherency and linear dispersion
- Passive and active versions available
- Passive versions with NL4 Neutrik Speakon in using 1+/-
- Active version with two class-D amplifiers with a total of 1200W RMS, and DSP with several presets and dedicated FIR-coefficients
- Coaxial design for linear point-source performance with phase-coherent dispersion
- Neodymium components for low weight
- Designed for high-power music and live performance reproduction
- Optimal for installing in fixed installations either horizontal or vertical
- A variety of easy-to-use rigging and installation hardwares available
- The two specially designed hardwares allows for quick-rigging with snap-in function.
- Two handles in the back for good functionality and discrete design.



Active versions

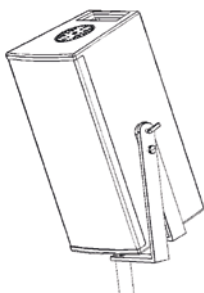

Quick-rigging hardware on stand

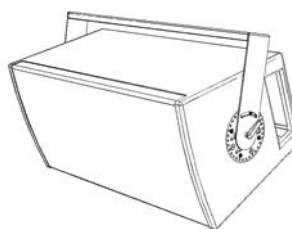

Installation bracket



Quick-rigging hardware on stand

MODEL	PX28	PX210	PX222	PX28A	PX210A	PX222A
Design	2-way passive point-source coax	2-way passive point-source coax	2-way passive point-source coax	2-way active point-source coax	2-way active point-source coax	2-way active point-source coax
Components	2 x 8" / 1"	2 x 10" / 1,3"	2 x 12" / 2"	2 x 8" / 1"	2 x 10" / 1,3"	2 x 12" / 2"
Power Handling cont.	1000W	1000W	1500W	1000W	1000W	1500W
Frequency response	60Hz + 19kHz	50Hz - 19kHz	50Hz - 19kHz	65Hz + 19kHz	55Hz - 19kHz	50Hz - 19kHz
Sensitivity	103dB	103dB	103dB	103dB	103dB	103dB
Max SPL (calc peak 2Pi)	136dB	137dB	138,5dB	136dB	137dB	138,5dB
Nominal Impedance	4 ohm	4 ohm	4 ohm	-	-	-
Dispersion	H100 x V100	H70 x V70	H60 x V40 rotatable	H100 x V100	H70 x V70	H60 x V40 rotatable
Dimensions	H50xW25xD25	H58xW30xD30	H68xW40xD40	H50xW27,5x25	H58xW30xD30	H68xW40xD40
Weight	11kg	15 kg	26 kg	13 kg.	17 kg.	28 kg
Amplifier channels	1	1	1	2 dsp-controlled	2 dsp-controlled	2 dsp-controlled
Additional information active version	-	-	-	1200W with DSP and presets, 90V-250VAC PFC wide voltage power input	1200W with DSP and presets, 90V-250VAC PFC wide voltage power input	1200W with DSP and presets, 90V-250VAC PFC wide voltage power input

Hardware

Installation-bracket, external top hat, Hook for truss, quick-rigging hardware, tilting cradle for adjustable aiming for portable use, on speaker pole with subwoofer or for truss-clamp

HX-SERIES

3-way hornloaded point-source speakers



INTRODUCTION

High-power, 3-way hornloaded point-source hybrid speakers for controlled dispersion, long throw and low distortion levels.

Designed for high power reproduction, FOH, live performance and music.

The HX-series can be used stand-alone fullrange, as top in portable systems with subwoofers, in installations or in compact large format live performance, flown or stacked.

With true 3-way design and seperated hornloaded midrange and highrange in combination with C.C.C. dipole low frequency transducer arrangement results in an extremely compact high-power speaker with low distortion, high sensitivity and astounding max SPL.

FEATURES

- Two sizes available in the series, both features active and passive versions.
HX8: 2x8" C.C.C. / 6,5"-hornloaded / 1" hornloaded
MX10: 2x10" C.C.C. / 8"-hornloaded / 1" hornloaded
- Active versions with built-in 1500W+2x375W RMS Class-D amplifiers and DSP with presets
- Passive versions with deticated passive crossover network 8 ohm speakon in two way using 1+1- for LF, and 2+2- for MF/HF, with a passive crossover handling MF/HF, using two amplifier channels on external 19" systems DSP-amplifier
- Long throw, controlled dispersion
- High sensitivity, low distortion and high max SPL
- Designed for high-end installations, portable use, PA-systems
- Extensive range of hardwares for rigging and installing available

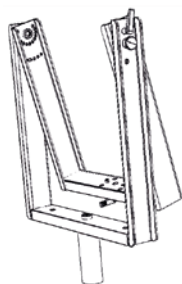

Cradle for using on speaker pole or on speaker stand for tilting

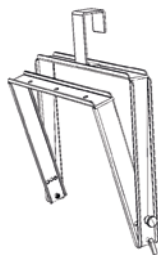

Cradle for installing with hook or clamp with adjustable tilt



HX8A with B18HPCA in an active portable sound system

MODEL	HX8	HX8A	HX10	HX10A
Design	3-way Horn-loaded point-source	3-way Horn-loaded point-source	3-way Horn-loaded point-source	3-way Horn-loaded point-source
Components	LF: 2 x 8" MF: 6,5" hornloaded HF: 1" driver on horn	LF: 2 x 10" MF: 8" hornloaded HF: 1" driver on horn	LF: 2 x 8" MF: 6,5" hornloaded HF: 1" driver on horn	LF: 2 x 10" MF: 8" hornloaded HF: 1" driver on horn
Power Handling cont. Impedance	LF: 1400W, 4ohm MF: 400W, 8ohm HF: 120W, 8ohm	LF: 1200W, 4ohm MF: 400W, 8ohm HF: 120W, 8ohm	LF: 1400W, 4ohm MF: 400W, 8ohm HF: 120W, 8ohm	LF: 1200W, 4ohm MF: 400W, 8ohm HF: 120W, 8ohm
Frequency responce	60Hz - 19kHz	50Hz - 19kHz	60Hz - 19kHz	50Hz - 19kHz
Sensitivity	105dB	107dB	105dB	107dB
Max SPL (calc. peak)	141dB	142dB	141dB	142dB
Dispersion	H80 x V60	H80 x V60	H80 x V60	H80 x V60
Dimensions	H67xW40/28xD48	H67xW40/28xD48	H80xW50xD50	H80xW50xD50
Weight	30 kg.	32 kg.	40 kg.	42 kg.
Amplifier channels	2	3	2	3
Active	No	Yes	No	Yes
Additional information active version	-	1500W + 375W x 375W with DSP and 4 presets 90-250V PFC wide volta-ge input	-	1500W + 375W x 375W with DSP and 4 presets 90-250V PFC wide volta-ge input

Hardware Installation-bracket, external top hat, Hook for truss, quick-riggin hardware, tilting cradle for adjustable aiming for portable use with speaker stand, speaker pole with subwoofer or with truss-clamp

CXL-SERIES

Coaxial multi purpose fullrange speakers



INTRODUCTION

The CXL-series is perfect for rental companies, PA-and event-companies due to the versatility and many features. Each speaker fetures monitor angle,two handles, wherein one discretely hides a top hat for mounting on speaker poles or speaker stands, there is an abundance of M10 threaded points for installation and rigging hardwares. The series can be used stand alone fullrange, as stage monitor or in a PA-system with subwoofers.

All models are available passive with deticated 8 ohm passive crossover, or active with built-in class-D amplifiers with several presets. (CXL8 only available passive)

FEATURES

- Four sizes available available le in the series, active and passive versions
- Active with built-in Class-D amplifiers and DSP with presets
- Passive with deticated passive crossover network 8 ohm Neutrik NL4 speakon in
- A total of seven models available, three active and four passive
- Can be used as stage monitors
- Can be used stand alone fullrange
- Can be used in sound systems with subwoofers, active or passive
- Perfect for small to medium size stages
- Designed for live performance, speech, vocals, acoustic instruments
- Neodymium components for light weight and high BL factor
- Sidefill, frontfill, delay-system, stand-alone, stage monitor, FOH and fixed iinstallation



CX12 in an active system with B18HPA subwoofer



CXL8 with the installation bracket



MODEL	CXL8	CXL10 (A)	CXL12 (A)	CXL15 (A)
Design	Multi-purpose front-loaded, direct radiating point-source neodymium coaxial fullrange speaker			
Components	8" with 2" voice coil 1"-with 1,7" voice coil	10" with 2,5" voice coil 1,3" with 2,5" voice coil	12" with 3" voice coil 2" with 3" voice coil	15" with 3" voice coil 2" with 3" voice coil
Power Handling cont	500W	500W	800W	1000W
Frequency rsonce	70Hz - 19kHz	60Hz - 18kHz	45Hz - 18kHz	40Hz - 18kHz
Sensitivity	100dB	100dB	102dB	102dB
Max SPL (calc. peak)	130dB	130dB	133dB	133,5dB
Nominal Impedance	8 ohm	8 ohm	8 ohm	8 ohm
Dispersion	100 nominal	70 nominal	60 x 40	60 x 40
Dimensions (mounted on top-hat)	H35 x W29,5 x D27,5	H45 x W33,5 x D29,5	H50 x W45 x D35	H60 x W55 x D40
Weight passive	10 kg.	13 kg.	17 kg.	21 kg.
Weight active	-	15 kg.	19 kg.	23 kg.
Amplifier channels passive version	1	1	1	1
Active version available	No	yes	yes	yes
Additional information active version	-	1200W class-D amplifiers with DSP and presets, 90-250VAC wide mains input PFC (Power Factor Correction) Powercon in/out, XLR in/out, FIR, 8 presets.		
Hardware	Installation bracket, rigging hardwares			

MX-SERIES

Compact 2-way coaxial point-source, low-profile, stage monitors

INTRODUCTION

Compact 2-way high-power coaxial point-source stage monitors with small footprint, low profile and nearfield listening angle of 15 degrees. Designed for small stages, auditoriums, conference centers, ensembles and tv studios. With a small footprint and low height, the MX-series is ideal for monitor listening where space is limited and the stage monitor is close to the user. The dispersion angle allows for standing or sitting close to the monitor and still retain on-axis fullrange frequency response. Available in active self-powered versions with on-board DSP and several presets, or passive version with built-in dedicated passive crossover network, using any of our external DSP systems amplifiers.

FEATURES

- Two sizes available in the series, active and passive versions
MX6: 6,5"/1" coax
MX8: 8"/1" coax (MX8A - active)
- Active with built-in Class-D amplifiers and DSP with several presets (MX8A)
- Passive with dedicated passive crossover network 8 ohm speakon in
- Very low profile, usable for TV and broadcast
- Listening angle of only 15 degrees for nearfield monitoring
- Perfect for small stages and close monitoring
- Designed for live performance, speech, vocals, acoustic instruments



M103F

Compact hybrid stage monitor with built in separate front-fill

INTRODUCTION

The M103F is a unique and innovative stagemonitor, next generation with built-in separate frontfill, for a clean and clutter-free stage, where usually, the front-fills compete with the stagemonitors for space on stage, giving an overall negative impression. With the M103F there is no need for external front-fills! In the front of the speaker is a separate 6,5"/1" coaxial speaker hidden behind the grille, with a hardware under the speaker for aiming the front-fill +/-120° horizontally. Speakon connectors in the bottom for discrete cabling, with 1+1- powering the 500W, 10"/1,3"-coaxial passive stage-monitor, and 2+2- powering the 300W, 6,5"/1" coaxial neodymium front-fill. Two separate 8 ohm passive crossovers for individual control of stage monitor and front-fill. FIR-filters presets available in all our 19" systems FIR DSP-amplifiers and the DSP4800 system processor.

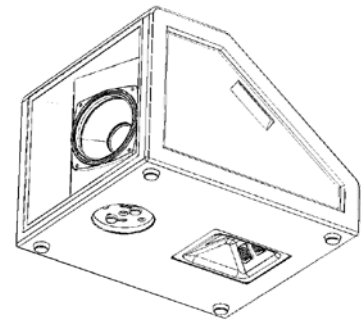

FEATURES

- Stage-monitor with 500W, 10"/1,3" coaxial
- Built-in, unique and innovative front-fill, 300W, 6,5"/1" coax
- Front-fill aimable +/- 120° horizontally
- Separate passive crossover for each speaker monitor/front-fill
- Neutrik NL4, 1+1- powering the stage monitor
- Neutrik NL4, 2+2- powering the front-fill
- Two linked Neutrik NL4 connectors hidden under the speaker
- Discrete cabling with input and link out under the speaker
- 8 ohm components
- Hardware under the speaker for aiming the front-fill horizontally
- Allows for any 4x4 speaker cable to fit under the speaker
- New design with two handles



MODEL	MX6	MX8	MX8A	M103F
Design	2-way passive coaxial low-profile stage monitor	2-way passive coaxial low-profile stage moitor	2-way active coaxial low-profile stage moitor	Hybrid combination stage-monitor with built in separate front-fill, 1+1- input for monitor, 2+2- input for front-fill, connectors mounted under
Components	6,5" with 2" voice coil 1" with 1,4" voice coil	8" with 2" voice coil 1" with 1,7" voice coil	8" with 2" voice coil 1" with 1,7" voice coil	Monitor: 10" / 1,3" Coax Front-fill: 6,5" / 1"-coax
Power Handling cont.	300W	500W	500W	monitor: 500W / Front-fill: 200W
Frequency response	80Hz - 19kHz	60Hz-18kHz	60Hz-18kHz	Monitor: 50Hz-18kHz / Front-fill: 90Hz-19kHz
Sensitivity	95dB	100dB	100dB	Monitor: 100dB / Front-fill: 93dB
Max SPL (calc. peak)	123dB	130dB	130dB	Monitor: 130dB / Front-fill: 120dB
Nominal Impedance	8 ohm	8 ohm	8 ohm	Monitor: 8 ohm / Front-fill: 8 ohm
Dispersion	70 nominal	100 nominal	100 nominal	Monitor: 70 nominal / Front-fill: 90 nominal
Dimensions	W20 x H17 x D30	W30 x H20 x D37	W30 x H20 x D37	W35 x H25 x D40
Weight	7 kg.	10 kg.	11 kg.	20 kg.
Amplifier channels	1	1	2	2
Active version	-	-	600W dsp-amplifier	-

PLA621

Very compact line array system



INTRODUCTION

The PLA621 is the smallest line array speaker in the PLA-family, designed for event, conference, live performance and installations in churches, schools, theatres, conference centers, auditoriums, sports facilities and small live stages.

With one 6,5" neodymium woofer and two 1" voice-coil drivers with 0,75" throat exit, the PLA621 is extremely compact and light in weight, with 3-point integrated line array hardwares for easy rigging and installing.

The PLA112 external 12" subwoofer can be used for extended low frequency reproduction. The subwoofer is available passive, or active, where the active version features 1500W amplification for the 12" woofer and an additional passive PLA112 subwoofer, and 2 x 750W amplification for driving a total of up to 8 pcs. of the PLA621 line array.

With presets for being a flown subwoofer, but also for being a LF-woofer with external subwoofers on the ground, where the PLA112 acts as a LF speaker to the PLA621 in a 3-way system, greatly enhances the Max SPL and power-handling, for larger events and performances.

FEATURES

- 1 x 6,5" + 2 x 1" components mounted on waveguides and horns
- 110 degree wide horizontal dispersion
- 15 degree controlled vertical dispersion
- Only W350 x H190 x D230 in size
- Can be ordered in any RAL colour upon request
- The PLA112 subwoofer is available active or passive, and can be added for extended LF either flown as subwoofer or LF in a 3-way system, or groundstacked as subwoofer
- The PLA112 subwoofer can be flown in array, or groundstacked, and is available active with 1500W + 2 x 750W for supplying up to 8 pcs. of the PLA621 in an array.
- Perfect for architectural installations
- Integrated 3-point rigging and line array hardwares
- Bumper frame with adjustable lifting angle
- Groundstackframe for mounting on subwoofers
- FIR-filter presets available in the V-series systems amplifiers and the DSP4800 systems processor

MODEL	PLA621	PLA112	PLA112A
Design	Line array with waveguide and horn	passive subwoofer for extended LF, flown or ground-stacked	Active subwoofer for extended LF, flown or groundstacked
Components	1 x 6,5" with 1,5" voice coil 2 x 0,75" with 1" voice coil	1 x 12" with 4" voice coil	1 x 12" with 4" voice coil
Power Handling cont.	300W	2000W	2000W
Frequency response	70Hz-19kHzHz	45Hz-120Hz	45Hz - 120Hz
Sensitivity	95dB	99dB	99dB
Max SPL (calc. peak) Array of 2x8	123dB 135dB	135dB -	135dB -
Nominal Impedance	8 ohm	8 ohm	8 ohm
Dimensions	W35xH19xD23	W35xH60xD60	W35xH60xD60
Weight	7,5 kg.	35 kg	40 kg.
Active version	no	No	Yes, with 1500W for driving itself and for driving one more external passive PLA112 subwoofer + 2x750W for driving up to 8 pcs. of PLA621



Six PLA621 in array

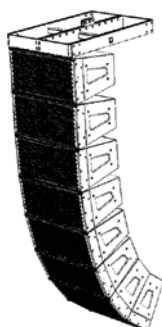

Eight PLA621 with bumper frame in array

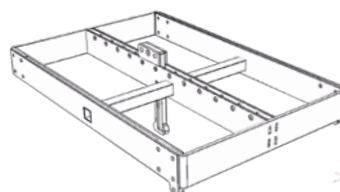

Bumper frame

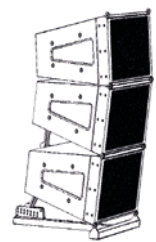

Groundstack frame

PLA2611_{v2}

High-power compact line array system



INTRODUCTION

The PLA2611 MK2 is the second generation with added functions, features and applications, such as 3-point rigging system instead of 4-point, for easier, quicker and safer rigging, collapsing rigging where the PLA2611 MK2 is stacked in a case collapsed, when rigging, just set the splay angles with the splay sprints, and lift the system up, each speaker will automatically position itself in the correct angle, if you want you can then secure with another splay sprint for extra security, reverse the order when it is time to take down the system.

The bumper frame features adjustable lifting points for optimal aiming precision.

There are an abundance of rigging and stacking hardware available for groundstack, cluster, front-fill and stand alone usage.

The latest FIR filters is applied, as in all our line array speakers in the PLA series, for optimal phase coherency.

Available in any color, for architectural installations

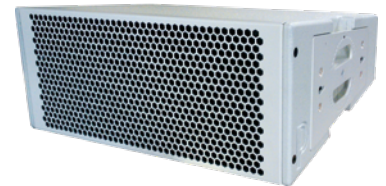

MODEL	PLA2611 MK2	PLA2611P MK2
Design	Active Line array	Passive line array
Components	2 x 6,5" / 1" driver mounted on waveguide and horn	
Power Handling cont.	600W	600W
Frequency response	60Hz - 19kHz	60z - 19kHz
Sensitivity	98dB	98dB
Max SPL (calc. peak)	129dB	129dB
Array of 8 (calc. peak)	146,5dB	146,5dB
Nominal Impedance	LF: 4 ohm / HF: 8ohm	8 ohm passive
Dimensions	W54 x H23 x D33	W54 x H23 x D33
Weight	17 kg.	15 kg.
Active version	Yes	No
Extended information active version	500W + 150W class-D, with switched mode wide mains power supply 90-240VAC, with PFC, 8 presets, FIR-filters, PowerCon True in/out, XLR AES / analogue in / out, 2 x RJ485 for daisychained network, rotary encoder for presets and gain.	

FEATURES

- 2 x 6,5" + 1" components mounted on waveguides and horns
- 110 degree wide horizontal dispersion
- 15 degree controled vertical dispersion
- Only W540 x H230 x D330 mm. in size
- Colapsing flywares for efficient rigging
- Available in active version with 500+150W amplifiers and DSP
- Active version features DSP with 8 presets and network
- Avaliabel in passive version with 8 ohm input
- Available in passive version with 16ohm input
- Can be ordered in any RAL colour upon request
- Perfect for architectural installations
- Integrated 3-point rigging and line array hardwares
- Bumper frame with adjustable lifting angle
- Groundstack frame for mounting on subwoofers
- FIR-filter presets available in the V-series systems amplifiers and the DSP4800 systems processor

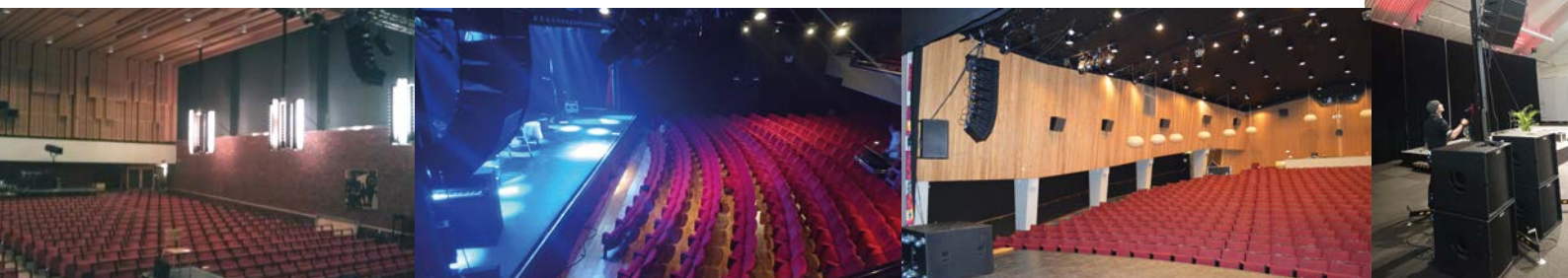

Collapsed in transportation case



Line array

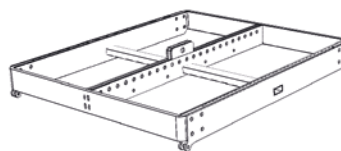

Bumper frame

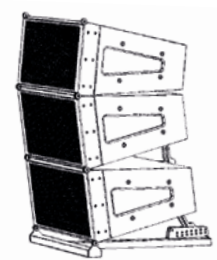

Groundstack frame

PLA2821_{v2}

High-power compact line array system



INTRODUCTION

Medium sized compact high-power passive or active line array speaker.

The unique design and arrangements of transducers results in a phase-coherent frequency response with symmetrical, controlled dispersion pattern, low distortion and high sensitivity.

The **PLA2821V2** is the perfect choice for installation in theatres, live stages, FOH, large churches and conference centers, and in sports arenas.

When it comes to festivals, tour and portable use the **PLA2821V2** is the natural choice for medium sized rental- and event- companies.

In combination with the **B318HPC**, 3x18" cardioid subwoofer, PLA2821V2 is a powerful line array system for medium sized events.

FEATURES AND SPECIFICATIONS

- 120 x 7,5 degree controlled dispersion
- Light weigh of only 24,5 kg. for the PLA2821PV2, and 26kg. for the PLA2821AV2.
- Integrated 4-point hardware and flightware
- 2 x 8" neodymium woofer mounted on soundguides
- 2 x 1" neodymium drivers mounted on waveguides and horn
- PLA2821PV2 Passive version with built-in 8 ohm passive crossover network
- PLA2821AV2 Active version with built-in 2x700W Class-D amplifiers and on-board DSP, for also supplying a passive PLA2821PV2 Line array speaker
- Two handles for easy rigging and handling
- Extensive rigging and installation hardwares and accesories available
- Power handling: 1000W cont.
- Sensitivity: 100dB
- Max SPL: 133dB single speaker (calc. peak)
- Max SPL: 151dB (eight speakers in an array, calc. peak)
- Dimensions: W760 x H280/215 x D400
- FIR-filter presets available in the V-series systems amplifiers, in the DSP4800 systems processor, and the PDSP-series DANTE amplifiers

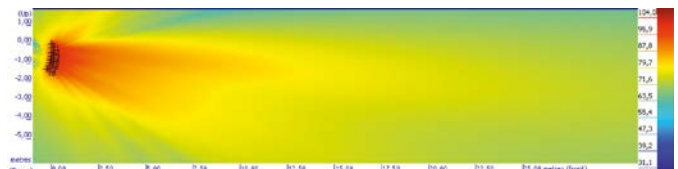
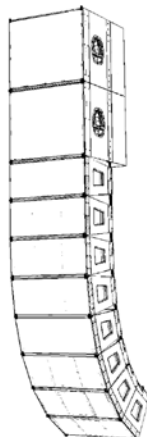
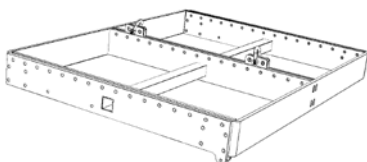
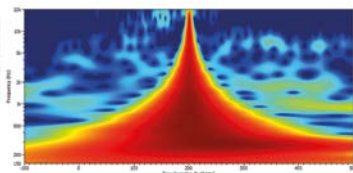

Simulation of PLA2821AMK2 in Ease focus2

PLA21021_{v2}

High-power compact line array system



INTRODUCTION

Medium sized compact high-power line array speaker with two 10" woofers mounted in a dipole configuration with two 1,4" drivers mounted on waveguide and horn.

The unique design and arrangements of transducers results in a phase-coherent frequency response with symmetrical, controlled dispersion pattern, low distortion and high sensitivity.

The **PLA21021** is the perfect choice for installation in theatres, live stages, FOH, large churches, conference centers and sports arenas.

When it comes to festivals, tour and portable use the **PLA21021** is the natural choice for medium sized rental- and event- companies.

In combination with the **B318HPC**, 3x18" cardioid subwoofer **PLA21021** is a powerful line array system for medium sized events.

Use the PLA215S or the PLA1812C flyable line array subwoofers for extended frequency response.

FEATURES AND SPECIFICATIONS

- 110 x 15 degree dispersion
- Light weight of only 20 kg.
- Integrated hardware and flightware
- 2 x 10" neodymium woofer mounted on soundguides
- 2 x 1" neodymium drivers mounted on waveguides and horn
- Available passive with built-in 8 ohm dedicated crossover network
- Available active with 1200W class-D amplifiers with DSP and presets
- Two handles for easy rigging and handling
- 4-point integrated flightware
- Extensive rigging and installation hardwares and accesories available
- Power handling 1000W cont.
- Sensitivity: 102dB
- Max SPL: 135dB single speaker (calc. peak)
- Max SPL: 153dB (eight speakers in an array, calc. peak)
- Dimensions: W600 x H310/255 x D400
- Weight: 20 kg. incl. integrated hardwares and flightwares
- FIR-filter presets available in the V-series systems amplifiers and the DSP4800 systems processor
- The PLA215S 2x15" flyable subwoofer, and PLA11812C flyable cardioid 18"/12" are designed to be used for extended low frequency response.



PLA212

High-power 3-way, 4-way and cardioid line array system

INTRODUCTION

Large format high-power line array module designed for live performance, festivals, club-events and installation in large theatres, churches, conference centers, live stages, sports arenas, venues and theme parks.

The PLA212 is available with two different dispersions; PLA212DF with H110 x V15, and PLA212LT with H80 x V10,

With four different versions of each.

- 1) 3-way passive bi-amplified, with dedicated passive crossover for MF/HF using a total of 2 external DSP-amplifier channels.
- 2) 3-way active, with 3kW class-D amplifiers (1500W+750W+750W) with DSP, presets, FIR, Network, AES and optional DANTE
- 3) 4-way passive cardioid, tri-amplified, using 3 external DSP-amplifier channels (LF, MF/HF, cardioid)
- 4) 4-way active cardioid with LF-1500W, MF/HF-750W, Cardioid-750W With DSP, presets, FIR, AES, network, and optional DANTE

FEATURES AND SPECIFICATIONS

- 110 x 15 degree dispersion PLA212DF
- 80 x 10 degree dispersion PLA212LT
- 3-way passive, 3-way active, 4-way passive cardioid, 4-way active cardioid
- Integrated hardware and flightware
- LF: 2 x 12" neodymium woofer in frontloaded tuned bassreflex design
- MF: 4 x 6,5" neodymium midrange woofers mounted in dipole configuration
- HF: 3 x 1" neodymium drivers with 1,7" voice coils mounted on waveguid and horn
- Cardioid: 2 x 8" neodymium woofers mounted in the back.
- Four handles
- 4-point integrated rigging hardware
- Power handling 4-way cardioid 4900W cont.
- Power handling 3-way 33500W
- Sensitivity: 106dB
- Max SPL: 145dB single speaker (calc. cont.) / 148dB (calc. peak)
- Weight: 66 kg passive 3-way version, 72 kg. passive 4-way version
- Dimensions: W110 x H400 x D400
- Adjustable lifting points in bumper frame for balancing the load of the array depending on til and number of speakers in the array, Lifting points can be used at 1, 2, 3 or 4 points, either center lifting, or sidelifting.
- FIR-filter presets available in the V-series systems amplifiers, DSP4800 system processor, and X-series amplifiers from powersoft

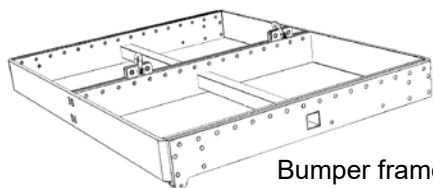

Bumper frame

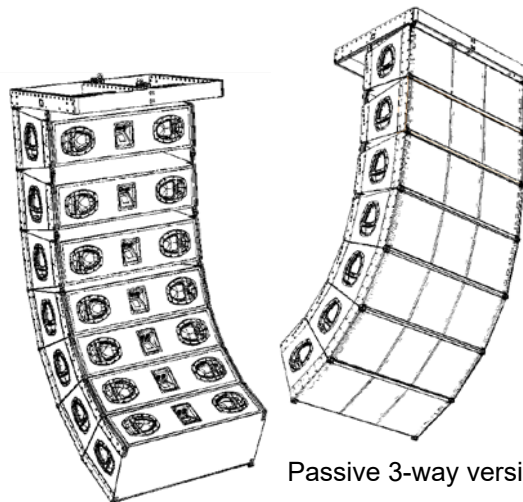

Passive 3-way version array

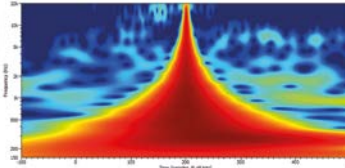

FIR filter coefficients for perfect phase, amplitude and delay alignment

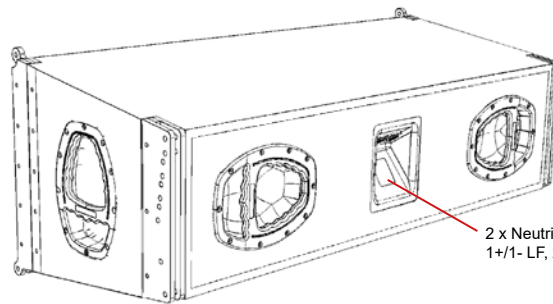

**3-way passive version
Bi-amplified**

2 x Neutrik NL4 Speakon
1+/1- LF, 2+/2- MF/HF

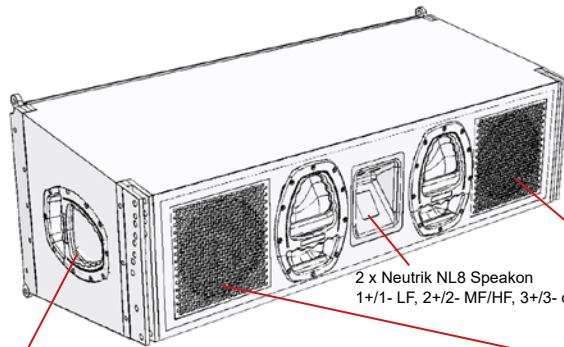

**4-way cardioid
passive version
tri-amplified**

2 x Neutrik NL8 Speakon
1+/1- LF, 2+/2- MF/HF, 3+/3- cardioid

2 x 8" Cardioid

4 handles with
ergonomical grip

4 x 6,5" MF-drivers in di-pole,
closed cabinet configuration

Integrated 4-point hardware
in 3x10 mm. construction
grade steel, for maximum
safety

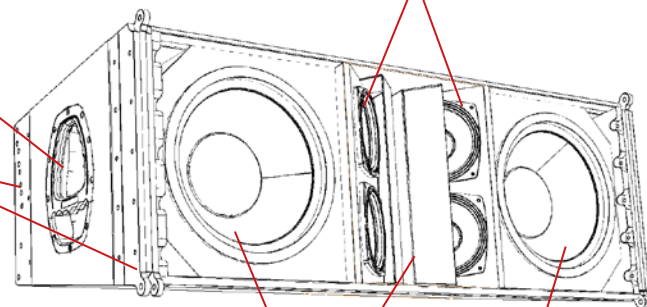

Horn and soundguide
for MF and HF

2 x 12" Neodymium woofers,
frontloaded, tuned bassreflex

PLA215S

High-power 2 x 15" line array subwoofer



INTRODUCTION

The PLA215S is a flyable and stackable high-power 2x15" subwoofer with C.C.C technology, with flyware integrated for connecting to the PLA21021FR flying frame, and the PLA21021 line array speaker.

The PLA215S can be used for groundstacking or for flying, the PLA21021FR line array flying frame fits the PLA215S and the PLA21021 with seamless integration, needing only one PLA21021FR flying frame for a complete array with both PLA215S and PLA21021. The special C.C.C (Common Compression Chamber) construction results in very high sensitivity and long-throw, both key features when flying subwoofers with line array. The 15" woofers feature Neodymium magnets for low weight and high BL factor. In larger venues and festivals, a separate array of PLA215S can be flown either behind or beside the main line array,

FEATURES AND SPECIFICATIONS

- 2 x 15" neodymium high-power woofers with 4" VC
- C.C.C. technology (Common Compression Chamber, for long throw)
- Available in passive 4 ohm
- Available active with 3200W amplifier with DSP and presets
- 4-point integrated rigging hardware
- Adjustable lifting points in bumper frame for balancing the load of the array depending on tilt and number of speakers in the array,
- Presets available in the V-series systems amplifiers, PDSP-series, DSP4800 system processor, and X-series amplifiers from powersoft
- Flyable subwoofer for PLA21021 (mk2) line array
- 35-150Hz frequency response (-6dB)
- Designed for extended LF in PLA21021 Line array system
- Compact format of 600x600x600 mm.
- Low weight
- 4 ohm impedance
- 105dB sensitivity
- 4000W continuous power handling (8000W peak)
- 144dB max SPL (Peak)
- Weight: 40 kg. incl. integrated hardware and flightwares
- The front is protected by 2 mm. thick, minimal airflow resistance, punched steel grille
- Protective speaker foam behind grille.

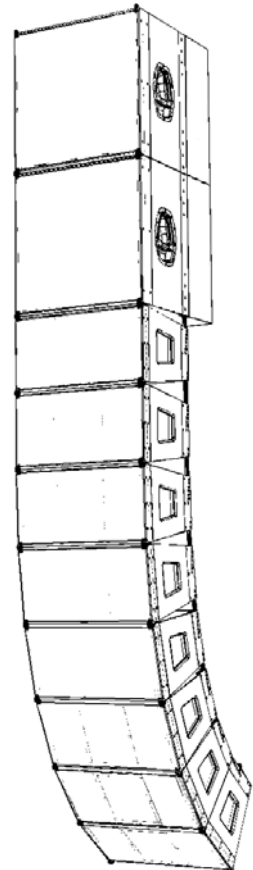
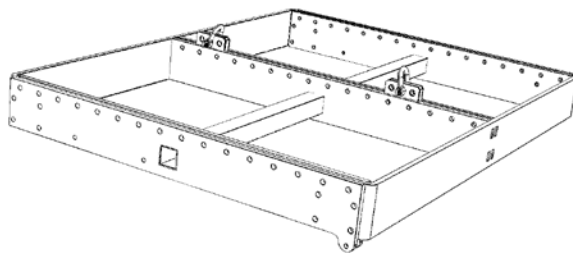

PLA1812C

High-power 1 x 18" / 1 x 12" cardioid line array subwoofer



INTRODUCTION

The PLA1812C is a flyable and stackable high-power 18"/12" cardioid" subwoofer with flyware integrated for connecting to the PLA21021FR flying frame, and the PLA21021 line array speaker.

The PLA1812C can be used for groundstacking or for flying, the PLA21021FR line array flying frame fits the PLA1812C and the PLA21021 with seamless integration, needing only one PLA21021FR flying frame for a complete array with both PLA1812C and PLA21021. The special cardioid configuration between the 18" woofer in the front and the 12" woofer in the back results in a controllable beam with very high sensitivity and long-throw, key features when flying subwoofers with line array. The woofers features Neodymium magnets for low weight and high BL factor.

In larger venues and festivals, a separate array of PLA1812C can be flown either behind or besides the main line array, or arrayed on the ground

FEATURES AND SPECIFICATIONS

- 18" / 12" neodymium high-power woofers with 4" VC
- Cardioid technology
- Available in passive 2 x 8 ohm
- Available active with 2 x 2000W amplifier with DSP and presets
- 4-point integrated rigging hardware
- Adjustable lifting points in the PLA210FR bumper frame for balancing the load of the array depending on tilt and number of speakers in the array,
- Presets available in the V-series systems amplifiers, PDSP-series, DSP4800 system processor, and X-series amplifiers from powersoft
- Flyable cardioid subwoofer for PLA21021 (mk2) line array
- 45-150Hz frequency response (-6dB)
- Designed for extended LF in PLA21021 Line array system
- Compact format of 600x600x800 mm.
- Low weight
- 2x8 ohm impedance
- 105dB sensitivity
- 4000W continuous power handling (8000W peak)
- 144dB max SPL (Peak)
- Weight: 50 kg. incl. integrated hardwares and flightwares
- The front is protected by 2 mm. thick, minimal airflow resistance, punched steel grille
- Protective speaker foam behind grille.
- passive version requires two amplifier channels and advanced DSP settings

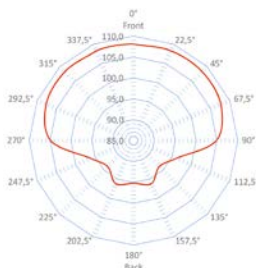
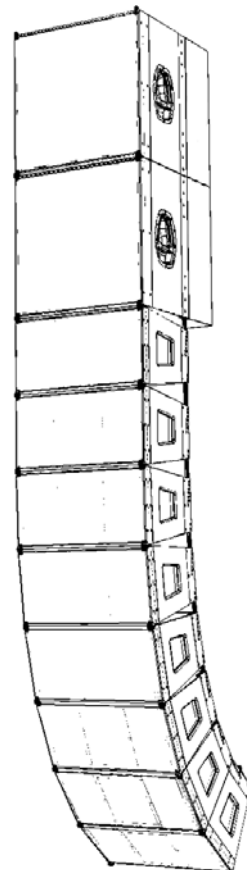
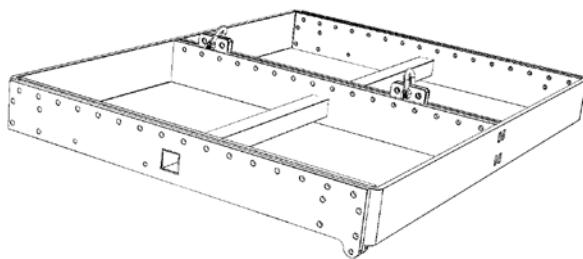

Average dispersion
31-100Hz, measured

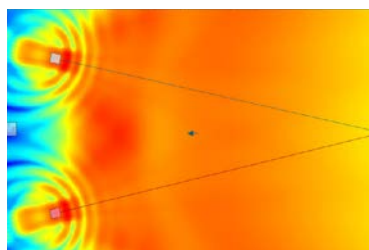

Cardioid subwoofer array

HPX-SERIES

High power subwoofers for tour and fixed installations



INTRODUCTION

The HPX-series high-power subwoofers is designed for reproducing controlled low frequencies at astounding high SPL with low distortion levels. designed for tour and installation with line array, point-source or hornloaded systems. All five models are available in passive version powered by any of our 19" systems DSP-amplifier, or active versions with built in amplifier modules and on-board DSP with several presets to chose from depending on application, setup and need. The HPX-series can be stacked, used in cardioid mode or end-fire array, presets and settings are available both for the active and passive versions.

FEATURES

- Six different models and sizes, where each model is available active or passive
- From single 18" compact subwoofer to 21" infra subwoofer and hornloaded 2x12"
- Front-loaded tuned bassreflex design (HB2121HPX hornloaded)
- Heavily braced cabinet design with special tour-enduring paint.
- Same presets in the DSP in the active versions as in the DSP in external 19" DSP systems amplifiers for the passive versions
- Cardioid presets available for optimal dispersion pattern and aimable cancellation
- Neodymium high-power magnet for linear excursion with very high power handling
- Very long peak to peak excursion
- Compact size



MODEL	B1HPX (A)	B18HPX (A)	B21HPX (A)	B2HPX (A)	B6HPX (A)	B221HPX
Design	Direct radiating, front-loaded tuned bassreflex					
Components	1 x 15"	1 x 18"	1 x 21"	2 x 15"	2 x 18"	2 x 21"
Power Handling cont.	3200W	3400W	4000W	6400W	6800W	8000W
Voice Coil	4,5" (116mm.)	4,5" (116 mm.)	6" (153 mm.)	4,5" (116 mm.)	4,5" (116 mm.)	6" (153 mm.)
Peak to peak excursion	60 mm.	60 mm.	60 mm.	60 mm.	60 mm.	60 mm.
Frequency rpsonce -6dB	35Hz-120Hz	30Hz-120Hz	25Hz - 100Hz	35Hz-120Hz	30Hz-120Hz	25Hz - 90Hz
Sensitivity	100dB	101dB	99dB	103dB	104dB	102dB
Max SPL (calc. peak)	140dB	138,5dB	138dB	143dB	144dB	144 dB
Nominal Impedance	8 ohm	8 ohm	4 ohm	4 ohm	4 ohm	2 x 4 ohm
Dimensions	W50xH50xD55	W60xH60xD65	W60xH80xD65	W50xH100xD60	W60xH120xD65	W60xH120xD80
Weight	45 kg.	56 kg.	65 kg.	90 kg.	110 kg.	130 kg.
Active version available	yes	yes	yes	yes	yes	yes
Active version available	4000W @4ohm / 3400W@8 ohm (2x2000W@2x8ohm) class-D amplifier with DSP, several presets, incl. cardioid setup. 90-240VAC wide power input. PFC (Power Factor Correction)					



HP-SERIES

High power subwoofers for portable sound and fixed installations.



B18HPA in a compact portable sound system, with a CXL15A, active 15" / 2" -coax, multi-purpose fullrange speaker

INTRODUCTION

Our HP-series, direct radiating front-loaded, tuned bassreflex subwoofers all features a special heavy braced cabinet construction for minimum loss in energy, all models can be used either as single ended, stacked in cardioid configuration or in end-fire array. For the passive versions, all presets are available in our 19" systems loudspeaker DSP and in our 19" DSP-systems amplifiers.

The active versions features a 2400W amplifier with DSP and presets,

FEATURES

- Five different models and sizes, where each model is available active or passive
- From single 12" compact subwoofer to double 18" subwoofer
- Front-loaded, direct radiating tuned bassreflex design
- Heavily braced cabinet design with special tour-enduring paint.
- Same presets in the DSP in the active versions as in the DSP in external 19" DSP systems amplifiers for the passive versions
- Cardioid presets available for optimal dispersion pattern and aimable cancellation
- Ferrite magnet with 4" voice coils
- Ventillated voice coil gaps, with double silicone spiders
- The active version features a 2400W class-D amplifier with DSP and presets

MODEL	B11HP (A)	B1HP (A)	B18HP (A)	B2HP (A)	B6HP (A)
Design	Active or passive direct radiating front-loaded tuned bassreflex				
Version	Passive / Active	Passive / Active	Passive / Active	Passive / Active	Passive / Active
Components	1 x 12"	1 x 15"	1 x 18"	2x15"	2 x 18"
Power Handling cont.	2000W	2000W	2400W	4000W	4800W
Voice Coil	4" (100mm.)	4" (100mm.)	4" (100mm.)	4" (100mm.)	4" (100mm.)
X max	9 mm.	9 mm.	9 mm.	9 mm.	9 mm.
Frequency responce	45Hz-150Hz	35Hz - 150Hz	30Hz-150Hz	35Hz - 150Hz	30Hz - 150Hz
Sensitivity	98dB	99dB	100dB	102dB	103dB
Max SPL (calc. peak)	137dB	138dB	139dB	141dB	142dB
Nominal Impedance	8 ohm	8 ohm	8 ohm	4 ohm	4 ohm
Dimensions	W40xH50xD50	W50xH50xD60	W60xH60xD65	W50xH100xD60	W60xH120xD65
Weight passive / active	35 kg. / 40kg.	40 kg. / 45 kg.	45 kg. / 50 kg.	75 kg. / 80 kg.	90 kg. / 95 kg.
Active version available	2400W class-D amplifier with presets, (omni, cardioid, music, live) 90-250VAC wide power input, PFC (PowerFactor Correction)				



HPC-SERIES

High power cardioid subwoofers for tour and fixed installations



INTRODUCTION

The flagship when it comes to low frequency emission and control, the HPC-series offers "out-of-the-box" cardioid configuration with drivers both in the front and in the back in a cardioid setup.

Using a combination of physical distance, delay, EQ, FIR and crossover in an advanced algorithm enables up to 18db of cancellation behind and on the sides of the subwoofers.

Whether using in fixed installations or for tour applications the HPC-series is appreciated by sound engineers, DJ's, musicians, event-companies and rental companies because of the many benefits with the cardioid technology, where the low frequencies are cancelled out behind, above and on the sides of the subwoofers, using that energy forwards, adding several dB in SPL on axis, raising the sensitivity and max SPL significantly.

FEATURES

- True cardioid behaviour "out-of-the-box"
- Using separate algorithms for each driver ensures optimal cancellation
- Up to 18dB cancellation
- Adding 2dB of SPL on axis
- Astounding max SPL
- "Behaves" as a horn, with -3dB loss of SPL for each doubling of distance.
- Relative compact format compared to max SPL and features
- Four models available in the series
- Active and passive versions available
- Designed for use with line array, horn-loaded, or other high SPL/long-throw systems
- Long throw

MODEL	B18HPC	B18HPCA	B318HPC	B318HPCX
Design	Cardioid high power subwoofers			
Components	Front: 1 x 18" Back: 1 x 12"	Front: 1 x 18" Back: 1 x 12"	Front: 2 x 18" Back: 1 x 18"	Front: 2 x 18" Back: 1 x 18"
Power Handling cont.	4200W	4200W	7200W	10200W
Voice Coil	4" (100 mm.)	4" (100 mm.)	4" (100mm.)	4,5" (116mm.)
Peak to peak excursion	60 mm.	60 mm.	60 mm.	60 mm
Frequency response	35Hz-120Hz	35Hz-120Hz	30Hz - 100Hz	30Hz - 100Hz
Sensitivity on axis	103dB	103dB	106dB	105dB
Max SPL (calc. peak)	142dB	142dB	147dB	148dB
Nominal Impedance	Front: 8 ohm Back: 8 ohm	Front: 8 ohm Back: 8 ohm	Front 4 ohm Back 8 ohm	Front: 4 ohm Back: 8 ohm
Dimensions	W50 x H72 x D92	W50 x H72 x D92	W60 x D88 x H120	W60 x D88 x H120
Weight	60 kg	65 kg	120 kg	130 kg
Active version available	2 x 1400W class-D amplifier with DSP, 90-250VAC wide mains in, PFC (Power Factor Correction) 4 presets DSP		no	no

Actual measured dispersion pattern of 2 pcs B318HPC in stack @ 2m.

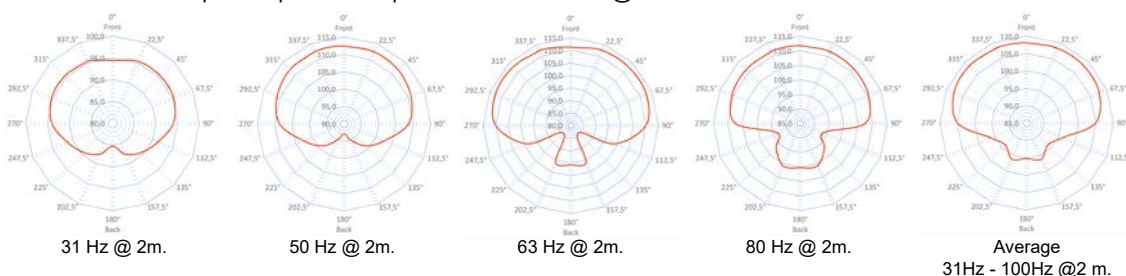

CLUBLAND

4-way hornloaded point-source high-power club systems



INTRODUCTION

The CLUBLAND-system was designed for high-end club installations and for club-events, either groundstacked FOH or flown. With 4-way system design and a combination of di-polar, C.C.C. (Common Compression Chamber) and hornloaded, the CLUBLAND delivers astounding max SPL with low distortion, long-throw and high headroom.

There are several modules in the series so that the user can choose between a variety of subwoofers and top modules, with two different MF/HF top modules, and three different subwoofers. When ordering the CLUBLAND system the horns, cabinets and grilles can be painted in any RAL colour for an architectural unique design, to enhance the visual experience in the club.

FEATURES

- Extreme max SPL
- Very high sensitivity
- Long-throw
- Designed for high-end nightclubs, events and dancefloors
- Combine your system according to your needs and preferred configuration.
- Two different hornloaded MF/HF modules
- Dedicated 2x15" dipol C.C.C. (Common Compression Chamber) LF module
- Three different subwoofer modules, 3x18" cardioid, 2x12" hornloaded, 2x21" front-loaded
- Stackable for FOH groundstacked
- Can be installed flown, using the many integrated fly-points.
- CLH81, CLH122 & CLV215 have several fly-points for installing in fixed high-end club installations
- Dedicated DSP-amplifier V10000 with 4x 2500W / 2x5000W with FIR-filters
- Can be ordered with any RAL colour combination on cabinet, horn and grilles
- Clubland is also available as active system, mainly used for portable club events



MODEL	CLH81	CLH122	CLV215	CLB318	CLB212	CLB221
Design	Hornloaded top	Hornloaded top	LF low mid C.C.C. (Common Compression Chamber)	Cardioid subwoofer	Hornloaded subwoofer	Front-loaded subwoofer
Components	8" / 1"	12" / 2"	2 x 15"	3 x 18"	2 x 12"	2 x 21"
Fly points	yes	yes	yes	no	no	no
Power Handling cont.	500W	1000W	4000W	10200W	4000W	8000W
Voice Coil	2,5"	3"	4"	4,5"	4"	6"
Frequency response	350Hz - 19kHz	100Hz - 18kHz	50Hz - 500Hz	30Hz - 120Hz	30Hz - 120Hz	25Hz - 90Hz
Sensitivity 1W/1m.	109dB	108dB	106dB	105dB	108dB	102dB
Max SPL (calc. peak)	143dB	145dB	143dB	147dB	148dB	144dB
Nominal Impedance	8 ohm	8 ohm	4 ohm	4 ohm / 8 ohm	4 ohm	2 ohm
Dimensions	W60xH60xD50	W60xH60xD60	W60xH60xD60	W60xH120xD85	W70xH100xD120	W60xH120xD80
Weight	30 kg	40 kg	40 kg	120 kg	125 kg	130 kg





INTRODUCTION

The CLAM21041 is a line array module for fixed installations. The specially designed horn and wave guides flattens the sound waves to a perfectly non-delayed symmetrical wavefront with a H110 x V15 dispersion pattern.

The passive 8 ohm construction allows for economical use of external amplifiers and DSP processors, (available FIR-presets in all our processors and amplifiers with built-in dsp's)

Since the CLAM line array are designed only for fixed installations, we have omitted all external features used in more advanced tour-friendly line arrays, to reduce manufacturing and materials cost, so that the module can perform like the most expensive tour line arrays, but cost a fraction, the splay tilting hardware was designed to be easy to use, safe and economical.

We have also analyzed how line arrays often are installed, where often two line array speakers are fixed in the same splay angle, so the CLAM are actually two medium sized line array modules in one cabinet...

Each driver and woofer has a perfect alignment, resulting in a seamless linear wave front. The cabinet were designed to be as shallow as possible (only 280 mm.) knowing that depth is often a problem when installing Line arrays.

SPECIFICATIONS

- 2 x 10" woofers, front-loaded direct-radiating tuned bassreflex
- 4 drivers mounted on waveguides and horns
- passive 2-way design with built-in dedicated passive crossover network
- 4 ohm impedance
- 110 x 15 dispersion pattern
- 100dB sensitivity, 1W/1m.
- 1200W cont. power handling
- Max SPL 137dB peak
- Speakon, phoenix or pole-terminals as connection options
- H570 x W520 x D280

FEATURES

- True line source coupling with a -3dB loss of SPL for each doubling of distance
- fixed hardwares for setting splay-angle 0°, 5°, 10°, 15°
- FIR filter presets in our system amplifiers and DSP's for optimal phase linearity
- Easy to install
- Bumper frame for flying, groundstack frame for mounting on subs
- Accessories such as bumper frame, groundstack frame and splay angle hardware
- High max SPL
- Controlled dispersion
- The PLA215S, 2x15" subwoofer can be used flown for extended LF response
- Shallow depth of only 280 mm. for installation in

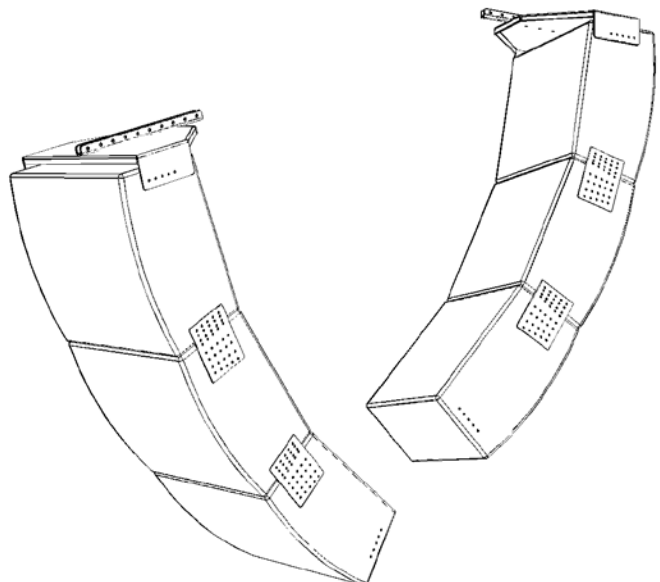
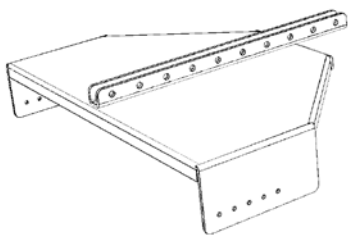

CS-SERIES

Ceiling speakers and in-wall speakers



INTRODUCTION

The CS-series, Architectural ceiling and in-wall speakers is used for installation in commercial audio and fixed installations, in restaurants, shops, malls, office, conference, leisure and the entertainment industry. several models and sizes, with Lo-Z 8 ohm and Hi-Z 100V with different power-taps. Available with white and black removable magnetic grilles.

2-way coaxial design for full frequency response, with frameless design and magnetic grille system for fast and secure installations, where the grilles are fastened on magnets, the grilles are available in black and white.

There are two models in the series: CS and CSX, where the CSX features a backcover, and the CS is open in the back for space-saving. The four quick installation arms enables fast and secure installations.

APPLICATIONS

- Conference centers
- Nightclubs
- Lounges and bars
- Restaurants
- Cruise ships
- Retail and shops
- Malls
- Leisure facilities and spaa
- Pools and swimming facilities
- Theme parks
- Training facilities



MODEL	CS502	CS602	CS802	CSX502	CSX602	CSX802	CS802SUB
Design	2-way passive ceiling and in-wall coaxial installation speakers						Ceiling subwoofer
Components	5"/1" tweeter	6,5"/1" tweeter	8"/1" tweeter	5"/1" tweeter	6,5"/1" tweeter	8"/1" tweeter	8" woofer
Power Handling cont.	40W	60W	80W	40W	80W	120W	500W
Frequency response (-6dB)	80Hz - 19kHz	65Hz - 19kHz	60Hz - 19kHz	80Hz - 19kHz	65Hz - 19kHz	60Hz - 19kHz	45-150Hz
Sensitivity 2Pi	89dB	90dB	91dB	89dB	90dB	91dB	95dB
Nominal Impedance	8 ohm	8 ohm	8 ohm	8 ohm	8 ohm	8 ohm	8 ohm
Hi-Z 100V transformer power taps	2,5W/5W/ 10W/20W	3,75W/7,5W/ 15W/30W	5W/10W/ 20W/40W	2,5W/5W/ 10W/20W	3,75W/7,5W/ 15W/30W	5W/10W/ 20W/40W	25W/50W/ 100W/200W
Dispersion	80° nominal	80° nominal	80° nominal	80° nominal	80° nominal	80° nominal	omni
Dimensions	Ø205 x D130	Ø235 x D98	Ø280 x D115	Ø205 x D130	Ø235 x D145	Ø280 x D190	600x600
Weight	1,3 kg	1,4 kg	1,8 kg	1,5 kg	2 kg.	2,7 kg.	8kg

PSC-SERIES

Pendant speakers

MODEL	PSC602	PSC802	CPSC802SUB
Design	2-way passive coaxial pendant installation fullrange speakers, tuned front-loaded bassreflex		pendant subwoofer, tuned front-loaded bass-reflex
Components	6,5"/1" driver	8"/1" driver	8"
Power Handling cont.	300W	400W	500W
Frequency response (-6dB)	80Hz - 18kHz	65Hz - 19kHz	50Hz - 200Hz
Sensitivity 2Pi	95dB	97dB	95dB
Nominal Impedance	8 ohm	8 ohm	8 ohm
Hi-Z 100V transformer	available external mounted		
Dispersion	70° nominal	100° nominal	Omni
Dimensions cm.	20 x 20 x 25	25 x 25 x 30	25 x 25 x 30
Weight	5 kg	7 kg	7 kg



INTRODUCTION

High power pendant speakers for architectural installations where controlled directivity, high SPL and wide frequency response is a demand, and where there are no walls or ceilings to mount speakers. The PSC-series is available in white and black.

The series features three different models, two fullrange coaxial speakers and one 8" subwoofer for extended low frequency response, for use in bars, lounges, nightclubs, restaurants etc.

VPX-SERIES

Fullrange multi-purpose speakers for installation and portable use



INTRODUCTION

The VPX-series is a range of multifunction plastic speakers designed for portable use and fixed installations, there are four sizes available: **VPX8**) 8"/1"-driver, **VPX10**) 10"/1"-driver, **VPX12**) 12"/1"-driver, **VPX15**) 15"/1"-driver, active or passive, where the active speakers features 700W (600W+100W) class-D amplifiers with advanced DSP-processors featuring a display, 4 different presets, 3 custom EQ-points, several modes: FULLRANGE, HP@80Hz, HP@100Hz, HP@120Hz, MONITOR, delay. The cabinet is made with a special polypropylene plastic, painted with the same speaker paint used on our speakers made in Plywood for a protective and esthetic surface. Fully covering speaker grille and vinyl cloth glued behind the grille protects the components, the passive versions features high-end 8-ohm passive crossover network. The speakers in the series all feature monitor angle for use as stage-monitors, several M8 points for flying and installing, top hat for mounting on speaker stand, several discretely hidden handles. In short, the VPX series is perfect for portable use, either as fullrange stand-alone, or with subwoofers in a sound-system, or in fixed installations fullrange or as top-speakers with subwoofers.

KEY FEATURES

- Designed for portable and installation
- Four sizes: 8"/10"/12"/15"
- 38 mm. driver mounted on horns
- 8 ohm passive versions / active selfpowered
- Neutral frequency response
- Monitor angle
- Top hat for mounting on speaker stand
- Several discrete handles
- Fully covering protective grille with speaker foam
- Plastic polypropylene cabinets,
- painted with external speaker paint
- Several M8 points for install and rigging

ACTIVE VERSIONS

- 24bit / 48kHz DSP
- 700W (600W + 100W) amplifiers
- Display
- 4 presets (music, vocal, DJ, acoustic)
- lightweight switch-mode power-supply
- Class-D amplifiers
- 3 custom EQ points with gain, frequency, Q-value
- Fullrange / HP mode
- Monitor preset
- Delay
- Easy to understand menu
- Rotary encoder for dsp-handling



VPX-SERIES
as stage monitor

Model	VPX8	VPX10	VPX12	VPX15	VPX8A	VPX10A	VPX12A	VPX15A
Power handling	200W	250W	350W	450W	200W	250W	350W	450W
Woofer inch (voice-coil)	8" (50 mm.)	10" (50mm.)	12" (65 mm.)	15" (76 mm.)	8" (50 mm.)	10" (50mm.)	12" (65 mm.)	15" (76 mm.)
Driver inch (voice coil)	1" (38mm.)	1" (38mm.)	1" (38mm.)	1" (38mm.)	1" (38mm.)	1" (38mm.)	1" (38mm.)	1" (38mm.)
Sensitivity, 1W/1m.	94 dB	95 dB	97dB	97dB	94 dB	95 dB	97dB	97dB
MAx SPL (*peak)	123dB	125dB	128dB	129dB	123dB	125dB	128dB	129dB
Nominal impedance	8 ohm	8 ohm	8 ohm	8 ohm	Active 8 ohm components			
Dimensions	47x29,5x26,5	53x34x32	60x38x36	TBA	47x29,5x26,5	53x34x32	60x38x36	TBA
Weight	12,5 kg.	15,5 kg.	18,75 kg.	22 kg.	12,5 kg.	15,5 kg.	18,75 kg.	22 kg.

VPS-SERIES

Wallmounted fullrange speakers for architectural installations



VPS4

APPLICATIONS

- Conference centers
- Nightclubs
- Lounges and bars
- Restaurants
- churches
- Cruise ships
- Retail and shops
- Malls
- Leisure facilities and spaa
- Pools and swimming facilities
- Theme parks
- Training facilities
- Recorded music,
- Acoustic performance
- Speech

INTRODUCTION

The VPS SERIES, a complete range of high quality 2-way fullrange installation speakers, VPS is short for Versatile Plastic Speakers, and that may be saying it all? A series of reliable speakers that fits everywhere, with their neutral design they blend in every possible installation, whether it being a bar or a restaurant, a shop or a mall, a conference room or a A/V room, even in a high quality home cinema.

There are four models of passive speakers that is available in black (B) or white (W), and one active version of the VPS602.

Each passive model has a built-in HI-Z 100V transformer with a select-switch in the back for easy setting different power-taps, they can also be run in LO-Z 8 ohm mode. When we started with the developing and designing process, we did not want to do "yet another plastic speaker" so very hard work was put into choosing components, designing crossovers and looking into the need and demand in these kind of speakers, talking to installers, project managers, architects and sound engineers, and after endless hours of testing and evaluating, both in our testing facility, our lab, and in numerous real installation environments the VPS series are born, after thousands upon thousands of VPS speakers sold, we can look back on all the work put into the series and say "it was worth it!"

With a neutral and clear sound, low distortion and wide frequency response the VPS-series are your perfect installation partner!

Developed to satisfy the demand in a series of fullrange installation speakers with a two-way design for speech and recorded music. They are easy to install and have a well balanced sound. The PROPHON VPS-series has been designed for use in restaurants, bars, shops, hospitals, schools, A/V-rooms, conference centres, malls, cruise-ships, and other leisure facilities, where design, sound quality and flexibility are essential.

There are several different mounting hardwares available for wall-mounting, included are the 'U'-brackets.

MODEL	VPS4	VPS502	VPS602	VPS602A	VPS802
Design	2-way passive (VPS602A - active) fullrange installation speakers				
Components	4"/1" coax tweeter	5"/1" tweeter	6,5"/1" tweeter	6,5"/1" tweeter	8"/1" tweeter
Power Handling cont.	40W	100W	120W	120W	160W
Frequency response (-6dB)	80Hz - 19kHz	70Hz - 19kHz	65Hz - 19kHz	80Hz - 19kHz	60Hz - 19kHz
Sensitivity 2Pi	88dB	90dB	91dB	89dB	90dB
Nominal Impedance	16ohm	8 ohm	8 ohm	8 ohm	8 ohm
HI-Z 100V transformer power taps	10W/20W	4W/8W/16W/30W	4W/8W/16W/35W	Active, 2x30W amplifiers	7,5W/15W/30W/60W
Dispersion	100° nominal	100° nominal	100° nominal	100° nominal	100° nominal
Dimensions HxWxD	130x130x140	240x180x145	290x215x165	290x215x165	350x270x180
Weight	2 kg	2,6 kg	4 kg	8 kg	7 kg



VPS4

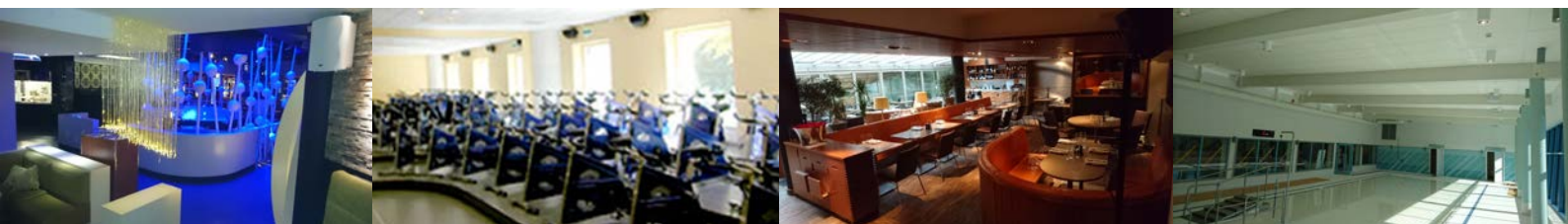

F-SERIES

Point-source 2-way fullrange high-power coaxial installation speakers



F6 / F6W

INTRODUCTION

The F-series is a range of high-end two-way point-source coaxial fullrange speakers for fixed installations in most applications. Coaxial design permits for a compact size with uniform directivity with controlled and coherent frequency response and linearity. There are six models in the series, all with timbre matching technology for allowing to install different models in the same installation without unmatched frequency response. Available in black and white, but can be ordered in any RAL color for architecturally challenging installations. The F-series is easy to install with the UB-brackets, allowing for precise aiming.

APPLICATIONS

- Conference centers
- Nightclubs
- Lounges and bars
- Restaurants
- churches
- Cruise ships
- Theme parks
- Sports arenas
- Live stages
- Recorded music,
- Acoustic performance
- Live performance

FEATURES

- 6 models from 6"/1" to 15"/2"
- High power handling
- Low distortion levels
- high sensitivity and max SPL
- Black and white available
- Can be ordered in any RAL colour
- Timbre matching
- Controlled dispersion
- Coaxial design for coherent frequency response
- FIR filters for perfect linearity
- Front-loaded, direct radiating tuned bassreflex design.
- Built-in dedicated passive crossover network
- 8 ohm

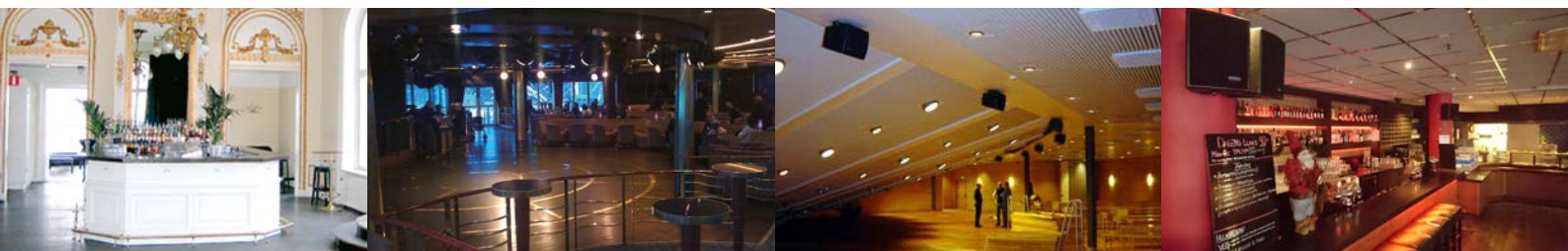

MODEL	F6	F8	F10	F12	F122	F152
Design	2-way passive point-source coax, tuned bass-reflex					
Components	6,5" with 2" VC 1" with 1,4" VC	8" with 2" VC 1" with 1,4" VC	10" with 2,5" VC 1" with 2" VC	12" with 2,5" VC 1" with 2" VC	12" with 3" VC 2" with 3" VC	15" with 3" VC 2" with 3" VC
Power Handling cont.	200W	400W	500W	500W	700W	800W
Frequency response (-6dB)	80Hz - 20kHz	65Hz - 20kHz	60Hz - 20kHz	50Hz - 20kHz	45Hz - 20kHz	40Hz - 20kHz
Sensitivity 2Pi	95dB	97dB	100dB	99dB	101dB	101dB
Max SPL (calc peak 2Pi)	126dB	128dB	131dB	135dB	137dB	138dB
Nominal Impedance	8 ohm	8 ohm	8 ohm	8 ohm	8 ohm	8 ohm
Dispersion	H90 x V90	H100 x V100	H90 x V60	H60 x V60	H80 x V80	H80 x V80
Dimensions (HxWxD)	22/16 x 26 x 20	27,5/19 x 35 x 27	34/26 x 46 x 28	43/30 x 54 x 38	43/30 x 54 x 38	H68xW40xD40
Weight	5kg	10 kg	11 kg	20 kg.	25 kg.	33 kg
Amplifier channels	1	1	1	1	1	1
Installation bracket	UB6	UB8	UB10	UB12	UB12	UB15

PI-SERIES

Point-source, 2-way fullrange installation speakers

INTRODUCTION

The Pi series is a versatile series of two-way point-source fullrange installation speakers, for a variety of applications, the series features four different models from 8" to 15".

All models can with ease be used in the same area because of the timbre- matching frequency response technology, where all speakers in the series has the same coherent frequency response, linearity and phase, solving the problems that often occur with other brands when mixing different speakers together, where the frequency response and timbre matching is not optimal, resulting in incoherent and badly tuned systems where the frequency response is unmatched and uneven, depending on where you are in the room.

Designed for installation in Schools, work-out facilities, pubs & bars, nightclubs, churches, sports-facilities, high-end karaoke, live-performance stages, hockey-rinks, theme-parks, cruise ships, spaa facilities, lounges etc.

FEATURES

- Four different sizes from 8"/1" to 15"/1"
- Point-source fullrange speakers
- High-end components ensures long lifespan with minimum service.
- Timbre matching technology allows seamless combinations of models
- High sensitivity, power handling and max SPL for installations
- Painted with a special hard laque for longevity and durability
- 1,2 mm. protective punched steel grilles with speaker foam behind
- Coated cones for withstanding moist environments
- Cabinet constructed of highly reinforced braced medium density fibreboard.
- Uniform V80 x H60 dispersion
- Can be ordered in any RAL colour for architectural installations
- Two versions of connectors available
 - 1) With 2 x NL4 Neutrik Speakon using 1+/1- in/out, and 2+/2- for link.
 - 2) With pole screw terminals (+) red positive, (-) black negative



Model	Pi81	Pi101	Pi121	Pi151
Design	2-way fullrange point-source front-loaded tuned bassreflex			
Components	8" woofer 1"- driver mounted on horn	10" woofer 1"- driver mounted on horn	12" woofer 1"- driver mounted on horn	15" woofer 1"- driver mounted on horn
Dispersion	H80 x V60			
Power handling				
RMS	120W	200W	300W	550W
Cont.	240W	400W	600W	1100W
Peak	480W	800W	1200W	2200W
Sensitivity 1W/1m. 2Pi	99dB	100dB	101dB	102dB
Max SPL cont. / peak 1W/1m.	123dB / 126dB	126dB / 129dB	128,5dB / 131,5dB	132,5dB / 135,5dB
Frequency response -6dB	65Hz - 19kHz	55Hz - 19kHz	50Hz - 19kHz	45Hz - 19kHz
Dimensions W x D x H (cm.)	44 x 28 x 28	53 x 33 x 33	55 x 37 x 41	62 x 40 x 45
Weight	15 kg.	17 kg.	19 kg.	23 kg
extra hardware	UB8 bracket	UB10 bracket	UB12 bracket	UB15 bracket

SL-SERIES

Installation subwoofers

INTRODUCTION

The SL-series subwoofers for fixed installations features five different models for a wide variety of applications and installations, designed for high end demanding installations in nightclubs, live performance, lounges, theme parks, cruise ships, theatres, conference centers, sports arenas, work out facilities etc. Heavily braced Medium Density Fibreboard cabinet ensures precise and controlled emission of low frequency reproduction, with front-loaded, direct-radiating, tuned bassreflex design for linear and coherent subwoofer design.

From the smallest S12L with 12" woofer designed for tight spaces yet where a powerful subwoofer must be installed to reproduce the LF needed, to the 2x18", 2,4kW high power subwoofer for large format nightclubs, events and live performance stages, where there can be no compromise in regards to SPL, power handling and frequency response.

Standard color is black, but the S-series can be ordered in any RAL color to blend into architectural designs to meet the demands of architects and designers.



FEATURES

- Five different sizes from 1x12" to 2x18"
- Direct radiating, frontloaded tuned bassreflex design for optimal frequency response and cone control
- High-end components ensures long lifespan with minimum service.
- 3" voicecoils with double copper wire
- Two versions of connectors available
 - 1) With NL4 Neutrik Speakon in using 1+/- in/out, and 2+/- for link.
 - 2) With pole screw terminals (+) red positive, (-) black negative
- Ventilated voice coil gaps for reduced power compression
- Designed for music, club and live performance reproduction.
- Double silicone spiders with optimized compliance
- High sensitivity, power handling and max SPL for installations
- Painted with a special hard laque for longevity and durability
- 1,5 mm. protective punched steel grilles with speaker foam behind, both with minimal air flow resistance
- Coated cones for withstanding moist environments
- Cabinet constructed of highly reinforced braced medium density fibreboard.

MODEL	S12L	S15L	S18L	S215L	S218L
Design	Front-loaded, direct radiating tuned bassreflex				
Components	1 x 12" with 3" VC	1 x 15" with 3" VC	1 x 18" with 3" VC	2 x 15" with 3" VC	2 x 18" with 3 VC
Power Handling cont.	900W	1100W	1200W	2200W	2400W
Frequency response (-6dB)	40Hz - 200Hz	40Hz - 150Hz	35Hz - 150Hz	40Hz - 150Hz	35Hz - 150Hz
Sensitivity 2Pi, 1W/1m.	98 dB	102 dB	102 dB	105 dB	105 dB
Max SPL (calc peak 2Pi)	131 dB	135 dB	135,5dB	141 dB	142 dB
Nominal Impedance	8 Ω	8 Ω	8 Ω	4 Ω	4 Ω
Dimensions (HxWxD)	50 x 40 x 40	60 x 48 x 54	73 x 55 x 60	100 x 50 x 55	118 x 60 x 60
Weight	25 kg	40kg	48 kg	76 kg	106 kg
Amplifier channels	1	1	1	1	1
Recommended amplifier power	300-1000W	500-1200W	1000-2000W	2000-4000W	2000-5000W
Recommended amplifiers: V10000, V3000, PX4DSP, PX8DSP, P41200DSP, P42400DSP					

S-SERIES

High-power installation subwoofers

INTRODUCTION

The S-series subwoofers for fixed installations features six different models for a wide variety of applications and installations, designed for high-end demanding installations in nightclubs, live performance, lounges, theme parks, cruise ships, theatres, conference centers, sports arenas, work out facilities etc. Heavily braced Medium Density Fibreboard cabinet ensures precise and controlled emission of low frequency reproduction, with front-loaded, direct-radiating, tuned bassreflex design for linear and coherent subwoofer design.

From the smallest S12 with 12" woofer designed for tight spaces yet where a powerful subwoofer must be installed to reproduce the LF needed, to the 2x18", 4,8kW high power subwoofer for large format nightclubs, events and live performance stages, where there can be no compromise in regards to SPL, power handling and frequency response.

Standard color is black, but the S-series can be ordered in any RAL color to blend into architectural designs to meet the demands of architects and designers.



FEATURES

- Seven different sizes from 8" to 21"
- Direct radiating, frontloaded tuned bassreflex design for optimal frequency response and cone control
- High-end components ensures long lifespan with minimum service.
- 4" voicecoils with double copper wire (6" VC in S121)
- Two versions of connectors available
 - 1) With NL4 Neutrik Speakon in using 1+/1- in/out, and 2+/2- for link.
 - 2) With pole screw terminals (+) red positive, (-) black negative
- Ventilated voice coil gaps for reduced power compression
- Designed for music, club and live performance reproduction.
- Double silicone spiders with optimized compliance
- High sensitivity, power handling and max SPL for installations
- Painted with a special hard laque for longevity and durability
- 1,5 mm. protective punched steel grilles with speaker foam behind, both with minimal air flow resistance
- Coated cones for withstanding moist environments
- Cabinet constructed of highly reinforced braced medium density fibreboard.

MODEL	S8	S12	S15	S18	S215	S218	S121
Design	Front-loaded, heavily braced, direct radiating tuned bassreflex						
Components	1 x 8" with 2" VC	1 x 12" with 4" VC	1 x 15" with 4" VC	1 x 18" with 4" VC	2 x 15" with 4" VC	2 x 18" with 4" VC	1 x 21" with 6" VC
Power Handling cont.	500W	2000W	2000W	2400W	4000W	4800W	4000W
Frequency response (-6dB)	50Hz - 200Hz	40Hz - 200Hz	35Hz - 150Hz	30Hz - 150Hz	35Hz - 150Hz	30Hz - 150Hz	25 - 120Hz
Sensitivity 2Pi, 1W/1m.	95 dB	98 dB	99 dB	100 dB	102 dB	103 dB	99 dB
Max SPL (calc peak 2Pi)	125 dB	134 dB	135 dB	137dB	141 dB	1423 dB	138 dB
Nominal Impedance	8 Ω	8 Ω	8 Ω	8 Ω	4 Ω	4 Ω	4 Ω
Dimensions (HxWxD) cm.	37 x 25 x 32,5	50 x 40 x 40	60 x 48 x 54	73 x 55 x 60	100 x 50 x 55	118 x 60 x 60	80 x 60 x 66
Weight	9 kg.	27 kg.	42 kg.	50 kg.	80 kg.	110 kg.	60 kg.
Amplifier channels	1	1	1	1	1	1	1
Recommended power	250W - 500W	1000W-2000W	1000W-2000W	1000W-2000W	2000-4000W	3000-5000W	3000-5000W
Recommended amplifiers: V10000, PX4DSP, PX8DSP, P41200DSP, P42400DSP, P4260DSP, P4800DSP							

P-SERIES

Affordable compact portable speakers



Two P118A subwoofers with two P121A on speaker poles, as top speakers in active system

INTRODUCTION

The P-series was designed as an affordable series, but still maintaining the prophon-quality. Four loudspeakers are available both in active and passive versions, two fullrange speakers, one 10"/1" (P101) and one 12"/1" (P121), with handles, top hat, monitor angle, rubber feets, The active versions features two class-D amplifier with a total of 600W and DSP with 4 presets. The two subwoofers in the P-.series features one 15" (P115, and one 18" (P118) where the active versione features a 1200W class-D amplifier with DSP and 4 presets. The P-series was designed for bands, DJ's schools, nightclubs, bars, lounges, themaparks and other application where an affordable sound system meets high quality.

FEATURES

- Affordable speakers with high value
- Two fullrange speakers in the series, P101 (10"/1") and P121 (12"/1")
- monitor angle on the fullrange speakers
- Two subwoofers, P118 with 18"-woofer and P115 with 15"-woofer
- Active versions available for each model
- A total of eight models, active and passive versions included
- High sensitivity, low distortion, controled dispersion, easy to use, reliable
- Designed for bands, DJ's, event companies, the rental industry
- Designed for installations in nightclubs, small live stages, FOH, lounges, schools etc.
- Stage monitor angle for use as stage monitors



The active versions features the new DSP platform with an abundance of functions and features.

- DSP with 4 presets, live, club, acoustic, vocal
- Rotary encoder for adjusting settings
- 3-band EQ for custom frequency response
- Selectable fullrange of adjustable HP-filter in the fullrange speakers.
- Adjustable LP-filter frequency in the subwoofers
- The fullrange speakers features two amplifiers with a total of 600W RMS (1200W peak)
- The subwoofers features a 1200W amplifier (2400W peak)
- Delay 0 - 1000mS for using as delay system
- preset for monitor use.
- 2 x Combo XLT/Tele in with selectable line or mic
- Separately and independent volume control on each input
- Sum XLR female out
- master gain / sum out gain using the rotary encoder
- PowerCon in/link out and on/off-switch

MODEL	P101 / P101A	P121 / P121A	P115 / P115A	P118 / P118A
Design	Fullrange speakers with monitor angle tuned bassreflex 2-way design, Passive or active		Direct radiating front-loaded tuned bassreflex subwoofers, passive or active	
Components	10" / 1" on horn	12" / 1" on horn	15"	18"
Power Handling cont.	300W	400W	1100W	1200w
Voice Coil	10" woofer: 2" voice coil 1" driver: 1,4" voicecoil	12" woofer: 2,5" voice coil 1" driver: 1,4" voicecoil	3"	3"
Frequency rponse	70Hz - 18kHz	60Hz - 18kHz	40Hz - 120Hz	35Hz-120Hz
Sensitivity on axis	100dB	100dB	102dB	102dB
Max SPL (calc. peak)	128dB	129dB	135dB	136dB
Nominal Impedance	8 ohm	8 ohm	8 ohm	8 ohm
Dimensions	W30 x H40 x D35	W35 x H45 x D40	W48 x D54 x H60	W55 x D60 x H72
Weight	15 kg / 17 kg.	20 kg. / 22 kg.	40 kg.	50 kg.
Extended information active versions	600W class-D amplifier, DSP with 4 presets, live, club, acoustic, vocal, 2 x mick/line in via combo XLR/TELE with seperate gain controls, 1 x XLR mix out, delay up to 1000mS, 3 x EQ points for custom EQ, monitor setup for use as monitor		1200W class-D amplifier, DSP with 4 presets, live, club, extended, acoustic, delay up to 1000mS	

PA-SERIES

Compact portable active and passive sound systems



INTRODUCTION

The A-series features several portable active and passive sound systems with subwoofers and top speakers, ranging from small systems to fairly large systems. The active systems uses built-in class-D amplifiers with DSP's and dedicated presets, the passive systems features our 19" 4-channels systems DSP-amplifiers. Designed for portable use by rental companies, event companies, bands, DJ's, and for fixed installations, live stages, clubs, lounges and bars.

FEATURES

- 10 different system, available both active or passive
- Designed for portable use and fixed installations
- Light weight neodymium components
- The active systems features built-in class-D amplifiers with DSP and several presets
- The passive systems features 4-channel 19" DSP systems amplifiers
- Designed for "on-the-road" handling
- Perfect for rental companies, event companies, traveling bands, DJ's
- Can be installed in fixed installations, live stages, FOH, clubs, conference, cruise ships, theme-parks.



NANO

The NANO sound system is our smallest and most compact point-source system, with 12" subwoofers and 6,5"/1" point-source coaxial top speakers, NANO handles acoustic performance, small live performances, DJ-sessions and conference easily.

The active version features 1000W + 2 x 500W DSP-controlled class-D amplifiers mounted in the active subwoofer, with several presets for different setups and applications, the active NANO system can support a total of two subwoofers, and four top speakers.

The passive version features the 19" 1RU DSP-systems amplifier **P426DSP** with 4x600W, the P426DSP amplifier can supply a total of 4 pcs. of subwoofers and 8 pcs. of top speakers.

FEATURES

- One 12" subwoofer
- Two F6X, 6,5"/1" compact coaxial neodymium top speakers
- Active version with 1000W + 2 x 500W in subwoofer
- Passive version with 4x600W 19", 1RU DSP-systems amplifier
- Active version support 2 subwoofers and 4 top speakers
- Passive version supports 4 subwoofers and 8 top speakers
- Perfect for small acoustic performances, DJ and conference
- High max SPL, low distortion
- Light weight, compact format
- Cases, transportation-bags, covers available as accessories
- Total power handling of 2000W cont.
- 90-250VAC wide mains input with PFC (Power Factor Correction)



A1

A1 is a compact high power sound systems for portable use and fixed installations, with B11 12" subwoofer and MF8 8"/1" point-source coaxial top speakers, for acoustic performance, small live performances, DJ-sessions, conference and fixed installations.

The active version features 1500W + 2 x 750W DSP-controlled class-D amplifiers mounted in the active subwoofer, with several presets for different setups and applications, the active NANO system can support a total of two subwoofers, and four top speakers.

The passive version features the 19" 1RU DSP-systems amplifier **P426DSP** with 4x600W, the P426DSP amplifier can supply a total of 4 pcs. of subwoofers and 8 pcs. of top speakers.

FEATURES

- Two B11, 12" subwoofers with 900W power handling each
- Two MF8, 8"/1" 500W top speakers with 100 nominal dispersion
- Active version with 1500W + 2 x 750W in subwoofer
- Passive version with 4x600W 19", 1RU DSP-systems amplifier
- Active version support 2 subwoofers and 4 top speakers
- Passive version supports 4 subwoofers and 8 top speakers
- Perfect for small acoustic performances, DJ and conference
- High max SPL, low distortion
- Light weight, compact format
- Cases, transportation-bags, covers castorplates available
- Total power handling of 2000W cont.
- 90-250VAC wide mains input with PFC (Power Factor Correction)



A2

The A2 features two 15" subwoofers and two 10"/1" point-source top speakers, designed for small to medium sized performances and club events, wherein the active versions each subwoofer houses 2 x 1050W DSP-controlled class-D amplifier with speakon output for driving the passive top speakers, the passive versions uses the 4 channel 19" class-D, systems DSP-amplifier with 4x750W

FEATURES

- Two 15" subwoofers, with 2000W power handling each
- Two 10"/1" top speakers with 90x60 dispersion
- Active version with 2 x 1050W class-D amplifier in each subwoofers
- Passive version with 4x750W 19", 1RU DSP-systems amplifier
- Passive version supports 4 subwoofers and 8 top speakers
- Perfect for small live performances, DJ and conference
- High max SPL, low distortion
- Light weight, compact format
- Cases, transportation-bags, covers castorplates available
- Total power handling of 5000W cont.
- 90-250VAC wide mains input with PFC (Power Factor Correction)

PA-SERIES

Compact portable sound systems



A3

The A3 features two 15" subwoofers and two 12"/2" point-source top speakers, designed for medium sized live performances, club events, the rental industry and fixed installations.

In the active versions each subwoofer houses 2 x 1050W DSP-controlled class-D amplifier with speaker output for also supplying the passive top speakers.

The passive versions uses the 4 channel 19" class-D, systems DSP-amplifier with 4x750W

FEATURES

- Two 15" subwoofers with 2000W power handling each
- Two 12"/2" top speakers with 80 nominal dispersion
- Active version with 2 x 1050W class-D amplifier in each subwoofers
- Passive version with 4x750W 19", 1RU DSP-systems amplifier
- Passive version supports 4 subwoofers and 8 top speakers
- Perfect for small live performances, DJ and conference
- Perfect for fixed installations in clubs, live stages, bars and lounges
- High max SPL, low distortion
- Light weight, compact format
- Cases, transportation-bags, covers available as accessories
- Total power handling of 5600W cont.
- 90-250VAC wide mains input with PFC (Power Factor Correction)



A4

The A4 features two B1HP, 15" subwoofers and two PX28, 2x8"/1" point-source top speakers, designed for medium sized live performances, club events, the rental industry and fixed installations.

In the active versions each subwoofer houses 2400W DSP-controlled class-D amplifier with 4 presets, incl. cardioid, each active PX28A houses 1200W class-D amplifier with DSP and 4 presets.

The passive versions uses the 4 channel 19" class-D, systems DSP-amplifier with 4x1500W

FEATURES

- Two 15" subwoofers with 2000W power handling each
- Two 2x8"/1" top speakers with 80 nominal dispersion
- Active version with 2400W class-D amplifier in each B1HPA
- Active version with 1200W class-D amplifier in each PX28A
- Passive version with 4x1500W 19", 1RU DSP-systems amplifier
- Passive version supports 4 subwoofers and 4 top speakers
- Perfect for live performances, DJ and conference
- Perfect for fixed installations in clubs, live stages, bars and lounges
- High max SPL, low distortion
- Light weight, compact format
- Cases, transportation-bags, covers castorplates available
- Total power handling of 600W cont.
- 90-250VAC wide mains input with PFC (Power Factor Correction)



A5

The A5 features two B18HP, 1x18" subwoofers and two PX210, 2x10"/1,3" point-source top speakers, designed for medium sized live performances, club events, the rental industry and fixed installations.

In the active versions each subwoofer houses 2400W DSP-controlled class-D amplifier with several presets incl. cardioid, the active PX210A features 1200W class-D amplifiers with DSP and several presets.

The passive versions uses the 4 channel 19" class-D, systems DSP-amplifier with 4x1500W

FEATURES

- Two B18HP, 1x18" subwoofers with 2400W power handling each
- Two PX210, 2x10"/1,3" top speakers with 80 nominal dispersion
- Active version with 2400W class-D amplifier in each B18HPA
- Active version with 1200W class-D amplifier in each PX28A
- Passive version with 4x1500W 19", 1RU DSP-systems amplifier
- Passive version supports 4 subwoofers and 4 top speakers
- Perfect for live performances, DJ and conference
- Perfect for fixed installations in clubs, live stages, bars and lounges
- High max SPL, low distortion
- Light weight, compact format
- Cases, transportation-bags, covers castorplates available
- Total power handling of 6400W cont.
- 90-250VAC wide mains input with PFC (Power Factor Correction)



A6

The A6 features four 1x18" subwoofers and two 2x10"/1,3" point-source top speakers, designed for medium sized live performances, club events, the rental industry and fixed installations.

In the active versions two subwoofer houses 2x1050W DSP-controlled class-D amplifier, also powering one passive slave sub each, and each top speaker houses a 1200W DSP-controlled class-D amplifier with several presets for different applications such as music, live, fullrange and monitor.

The passive versions uses the 4 channel 19" class-D, systems DSP-amplifier with 4x1500W

FEATURES

- Four 2x18" subwoofers with 4000W power handling each
- Two 2x10"/1,3" top speakers with 80 nominal dispersion
- Active version with 2 x 1050W class-D amplifier in two subwoofers, also powering two passive slave subwoofers each, and 1200W class-D amplifier with DSP in each top speaker
- Passive version with two 19", 1RU DSP-systems amplifier 2x1500W + 4x1500W
- Passive version supports 8 subwoofers and 8 top speakers
- Perfect for live performances, DJ and events
- Perfect for fixed installations in clubs, live stages, bars and lounges
- High max SPL, low distortion
- Light weight, compact format
- Cases, transportation-bags, covers castorplates available
- Total power handling of 9600W cont.

PA-SERIES

Compact portable active and passive sound systems



A7

The A7 features Two 2x18" subwoofers and two 2x12 1/2" point-source top speakers, designed for medium sized live performances, club events, the rental industry and fixed installations.

In the active versions each subwoofer houses 2x2000W DSP-controlled class-D amplifier and each top speaker houses a 1500W DSP-controlled class-D amplifier with several presets for different applications such as music, live, fullrange and monitor.

The passive versions is powered by the 1RU, 19" 4x5200w system amplifier P4XDSP, with 4x3500W in 4 ohm, with FIR, AES, PFC, network, wide mains in.

The P4XDSP can power a total of 4 x B6HP and 4 x PX222, allowing for expanding the system, but still running it on a single 1RU amplifier.

FEATURES

- Two 2x18" subwoofers with 4800W power handling each
- Two 2x12 1/2" top speakers with 80 nominal dispersion
- Active version with 2x2000W class-D amplifier in each subwoofers and 1500W class-D amplifier in each top speaker
- Passive version with 2x3000W 19", DSP-systems amplifier powering the subwoofers, and 2x1500W powering the top speakers
- Perfect for live performances, DJ and events
- Perfect for fixed installations in clubs, live stages, bars and lounges
- High max SPL, low distortion
- Light weight, compact format
- Cases, transportation-bags, covers castorplates available
- Total power handling of 11600W cont.
- 90-250VAC wide mains input with PFC (Power Factor Correction)



A8

The A8 features four 18" subwoofers and two 15 1/2" point-source top speakers, designed for medium sized live performances, club events, the rental industry and fixed installations.

In the active versions each subwoofer houses a 1500W DSP-controlled class-D amplifier and each top speaker houses a 1200W DSP-controlled class-D amplifier with several presets for different applications such as music, live, fullrange and monitor.

The passive versions uses the 4 channel 19" class-D, systems DSP-amplifier with 4x1500W

FEATURES

- Four 18" subwoofers with 2400W power handling each
- Two 15 1/2" top speakers with 80 nominal dispersion
- Active version with 1500W class-D amplifier in each subwoofers and 1200W class-D amplifier in each top speaker
- Passive version with 4x1500W 19", 1RU DSP-systems amplifier
- Passive version supports 4 subwoofers and 8 top speakers
- Perfect for acoustic performances, DJ and events
- Perfect for fixed installations in clubs, live stages, bars and lounges
- High max SPL, low distortion
- Light weight, compact format
- Cases, transportation-bags, covers castorplates available
- Total power handling of 12000W cont.
- 90-250VAC wide mains input with PFC (Power Factor Correction)



HX

The HX features two 18 1/2" cardioid subwoofers and two 2x8 5/8 1/2" hornloaded 3-way point source top speakers. Designed for medium to large sized live performances, club events, the rental industry and fixed installations.

In the active versions each subwoofer houses 2x1500W DSP-controlled class-D amplifier and each top speaker houses a 1500W+750W+375W DSP-controlled class-D amplifier with several presets for different applications such as club music or live performance.

The passive versions uses the 8 channel 19" class-D, systems DSP-amplifier with 8x1500W able to support a total of four subwoofers and eight top speakers.

FEATURES

- Two 18 1/2" cardioid subwoofers with 4400W power handling each
- Two 3-way hornloaded point-source top speakers with 2x8" dipole / 6,5"-hornloaded / 1" driver on horn
- Active version with 2x1500W class-D amplifier in each subwoofers and 1500W+750W+375W class-D amplifier in each top speaker
- Passive version with 8x1500W 19", 2RU DSP-systems amplifier
- Passive version supports 4 subwoofers and 8 top speakers
- Perfect for acoustic performances, DJ and events
- Perfect for fixed installations in clubs, live stages, bars and lounges
- High max SPL, low distortion longthrow
- Light weight, compact format
- Cases, transportation-bags, covers castorplates available
- Total power handling of 12000W cont.
- 90-250VAC wide mains input with PFC (Power Factor Correction)



AX

The AX system with cardioid subwoofer technology and line source was designed for large format live performance, FOH, club events and fixed installations where dispersion, control and long throw is essential. With three PLA21021, 2x10"/2x1" line array modules on each side, groundstacked on the B318HPC, 3x18" cardioid subwoofer, powered by the P4XDSP, 4x5200W 19" DSP-systems amplifier housed in one of the "dummies" placed in between the subwoofers and the line array speakers, also functioning to raise the height of the array to a proper height.

FEATURES

- Two B318HPC cardioid subwoofers with 7,2kW power handling each
- Six PLA21021 line array modules with 2x10"/2x1" each
- Only available in passive version with V20000, 4x5000W 19", 2RU DSP- systems amplifier mounted in the "dummy"
- Perfect for live performances, club and events
- Perfect for fixed installations in clubs, live stages, FOH
- High max SPL, low distortion longthrow
- Cases, transportation-bags, covers castor-plates available
- Including groundstack frame and rigging hardware
- Total power handling of 12000W cont. total power 20 000W
- 90-250VAC wide mains input with PFC (Power Factor Correction)

CA-SERIES

Column Array systems for portable use and fixed installations, active and passive

INTRODUCTION

The CA-SERIES Column Array Systems for portable use and fixed installations are available in active and passive versions and in several different sizes and configuration. The CA series is used for portable applications such as conference, live performance, music reproduction, and for fixed installations in churches, schools, conference centers, theatres, auditorium and live stages.

The CA11 features the CLA835" column line array speaker with 8x3,5 drivers and 12" subwoofer with 900W power handling.

The CA12 features the CLA4611 column line array speaker with 4x6,5"/1"coa and either 15" subwoofer or 18" subwoofer depending on application, need and preference.

Both the CA11 and CA12 series is available in four different configurations and sizes.

The CA-systems is available in active self-powered versions with built in amplifiers in one of the subwoofers,

where the CA11 systems features 1000W + 2 x 500W, and the CA12-system features 2500W + 2 x 800W

The passive versions uses external 4-channel 19" DSP-systems amplifier.

FEATURES

- A total of 8 different systems and sizes for a variety of applications
- Line array technology for long throw, and controled vertical dispersion of 20 degrees (depending on length of array)
- Wide horizontal dispersion of 120 degrees
- All amplifier features 90-250VAC wide mains input with PFC (Power Factor Correction)
- CA11-system available active with all amplification and processing housed in one subwoofer, with 1000W + 2 x 500W, able to power a total of two subwoofers and four column array speakers
- CA12-system available active with all amplification and processing housed in one of the subwoofers, with 2500W + 2 x 800W able to power a total of two subwoofers and four column array speakers
- Smart rigging hardware for quick rigging and assembly
- Avaliabel in any RAL colour for architectural installation
- Perfect for live performance, speech, vocals, acoustic music and recorded music
- Designed for installations in live stages, theatres, auditoriums, churches, conference centers etc.



White system, popular for conference, weddings, and installation in churches and other architectural installations.



CA11-1



CA11-2



CA11-3



CA11-4



CA12-1



CA12-2



CA12-3



CA12-4

4-Channel networked systems FIR amplifiers with DSP and loudspeaker-database



Database with all our speakers, with FIR filter coefficients for perfect phase, amplitude and delay alignment

INTRODUCTION

The V-series Pro-amp systems amplifiers was designed for pro-audio touring and fixed installations. Featuring three models, V6000, V10000 and V20000, 4-channel amplifiers with DSP, matrix, Network, FIR (AES / DANTE optional) With all prophon speakers stored in the internal loudspeaker database for accessing, routing and using in any combination and any configuration, so that the user can build and set up presets and configurations according to need and application. With the user-friendly touch-display all features can be managed without using a computer. Up to 256 amplifiers can be connected in a daisy-chained network, using the dedicated software, where amplifiers, speakers and channels can be grouped in several layers and depth, linked, assigned and managed with EQ on each channel, delay, crossover. The V-series can be used in fixed installations, portable use or tour, we also offer our PRO-AMP 19" RACKS ready to go, with PDU's, amplifiers and connection panels mounted in either tour-racks, or installation racks, depending on need and application.

FEATURES

- Five models available: V6000 with 6000W, V10000D with 10000W, V14000D with 14000W and V20000D with 20000W
- Load stabile in 8-2 ohm Lo-Z and 100V Hi-Z
- Optional DANTE™ 4x4 and AES67 for advanced networking and audio over network.
- Class-D and SMPS with wide mains in 90-264VAC, with PFC
- 4 INPUT / 4 OUTPUT fully routable DSP matrix topology
- Daisy-chained network via two RJ485 connectors
- Mains power input 170-265VAC
- 5:th generation switched mode power supply for light weight and stabile mains power.
- 4,3" IPS touch-display with access to all functions, addressing speaker-models to channels, and for editing and setting up your system.
- Rotary encoder for fast access and editing
- All prophon loudspeaker presets fully accessible, assignable and routable from the internal loudspeaker database with several modes for each loudspeakers, such as monitor, fullrange, High-Pass, line array
- Advanced FIR filter coefficients for phase-coherent and time-aligned frequency response
- 6 User EQ, crossover, gain, delay for system integration, room calibration and system tuning
- Intuitive software for managing networked systems or stand-alone amplifiers.
- User presets in the internal memory for storing custom setups, scenes and configuring custom systems
- Smart™ software integration,
- Limitless Grouping of several amplifiers and amplifier channels, with **gain, delay, PEQ, AA comp-group, alert monitor group** (with power, fault, Z and temp), **advanced group** (with gain, delay, EQ, Mute),



MODEL	V6000D	V10000D	V14000D	V20000D
Total output power PDU	5000W	10000W	14000W	20000W
Power All channels driven, LO-Z	4 x 1250 @ 8 Ω 4 x 1250 @ 4 Ω 4 x 1250 @ 2 Ω	4 x 1250W @ 8 Ω 4 x 2500W @ 4 Ω 4 x 2500W @ 2 Ω	4 x 1800W @ 8 Ω 4 x 3500W @ 4 Ω 4 x 3500W @ 2 Ω	4 x 2500W 4 x 5000W 4 x 5000W
Power per channel max (power-sharing)	1250W @ 8 Ω 2500W @ 4 Ω 1450W @ 2 Ω 1700W @ 2,67 Ω	1300W @ 8 Ω 2500W @ 4 Ω 2500W @ 2 Ω 3300W @ 2,67 Ω	1900W @ 8 Ω 3750W @ 4 Ω 3500W @ 2 Ω 4700W @ 2,67 Ω	3000W @ 8 Ω 6000W @ 4 Ω 5000W @ 2 Ω 6700W @ 2,76 Ω
Power All channels HI-Z (100V) Power All channels HI-Z (70V)	4 x 800W 4 x 1500W	4 x 2500W 4 x 2500W	4 x 3500W 4 x 2950W	4 x 5000W 4 x 3500W
Bridged mode (BTL) LO-Z	2 x 2500W @ 4, 8 Ω	2 x 5000W @ 4, 8 Ω	2 x 7000W @ 4, 8 Ω	2 x 10 000W @ 4, 8 Ω
Max output voltage and current rated Ampere 1/8 power	144 V _{peak} / 38 A _{peak} 15A @230V/4Ω	150 V _{peak} / 50 A _{peak} 7,3A @230V/4Ω	189 V _{peak} / 59 A _{peak} 10A @230V/4Ω	235 V _{peak} / 71 A _{peak} 14A @230V/4Ω
Frequency response (+/- 0,8dB)	20 Hz - 20 kHz			
S/N (20Hz - 20kHz)	106dB	111dB	113dB	115dB
THD+N 1/2 Power	< 0,05%			
Mains power	SMPS, Wide mains 90V-265VAC, class-D			
Connectors	4 x XLR analogue female input / 4 x XLR analogue male output (D), 4 x NL4 Speakon output, 2 x RJ485, 1xNL8 speakon output (D) available with DANTE™ and/or AES3/AES67 as, 16A Neutrik PowerCon on V6000D and V10000D, PowerCon 32A Neutrik PowerCon on V14000W and V20000D			
DSP	4 channel (2 AES pairs input. 4x4 DANTE option) Double 96kHz / 64 bit floating point asynchrony high-resolution sample rate converter (SRCs), 1000 TAPS FIR filter on each output,			
Dimensions	483 x 89 x 355	483 x 89 x 355	483 x 89 x 355	483 x 89 x 355
Weight	7 kg.	7 kg.	9 kg.	9 kg.

Dolby and the double-D symbol are registered trademarks of Dolby Laboratories Licensing corporation.

2 and 4-Channel DSP-amplifiers



INTRODUCTION

The PDSP-series, 2 and 4-channel class-D amplifiers with DSP is perfect for fixed installation and portable use, featuring 16 EQ points on all input and output channels, matrix routing, crossover 12-48dB on all output channels, limiter, delay, gain and all relevant Biquads. All functions can be managed using the buttons on the front panel or the GUI software. There are two models in the series with P21000DSP with up to 2x2100W, and P41000DSP with up to 4 x 1650W, P21000DSP features both XLR input and link out, P41000DSP features balanced XLR input.

FEATURES

- 2-4 channel Class-D amplifier with 92% efficiency for high power density
- with up to 2300W / channel
- Wide mains input 90-264VAC, 50-60HZ
- PFC, (active) Power Factor Correction, for reliable and stable power
- R-SMPS, Switched mode Power Supply
- Powerful DSP built in with EQ, delay, limiter, crossover, matrix signal routing
- LLC Soft start
- Multi-layered protection systems with Soft start, DC short circuit, overheat, overload, clipping/distortion limits
- High-end A/D, D/A converters
- Powerful processing with 32-40Bit floating DSP, 96kHz, 24-bit
- FIR filters with up to 896TAPS @ 96kHz custom algorithms, and most filter types and window types.
- With unique peak-limiter and ripple cancellation
- Designed for tour, portable use and installation
- Full color, graphic display with smart menu-system for easily adjusting parameters
- Front to back heat-controlled ventilation, with removable grilles for service and cleaning of accumulated dust in the filter
- Balanced XLR signal input and balanced XLR link output (link out only 2 channel amplifiers)
- P21000DSP/P4000DSP: 8 ohm, 4 ohm and 2 ohm use. (bridged use in 8 ohm and 4 ohm, not in 2 ohm)
- P6000DSP: 8 ohm, 4 ohm use (bridge use 2 x 8 ohm only)
- DANTE™ available as option

DSP FEATURES

- All parameters can be set either using the graphic full color display and the smart rotary-encoder, on the front panel of the amplifier, or via the GUI software
- 96kHz samplig rate, 32-40Bit floating DSP, 24-bit A/D, D/A conversion
- Full color, graphic display
- Total freedom in signal routing in to out, with individual gain structure on all in to out
- Gain adjustable range +15dB to -40dB, on all input and all output
- All parameters with copy and paste function for fast and easy operation
- All parameters can be linked with other channels individually
- Input gain sensitivity 26dB, 29dB, 32dB, 35dB
- Phase reverse option on all inputs individually
- 16 Biquads on all input and all outputs, with: PEQ, Low-shelf, High-shelf, Low, pass, High-pass, band-pass, all-pass 0,5-15Q, 20Hz-20kHz, -15 to +15 dB gain.
- Bypass and flat on all EQ's for quick testing and re-setting of channels
- Delay shown in mS and cm. from 0 to 120mS (41,160 m.) on all input and 0 to 2000mS (686 m.) all output channels
- High-pass and Low-pass filter crossover on all outputs individually, from off, to 20Hz to 20kHz
- With Linkwitz-Riley, Bessel, Butterworth types of slopes, 6-48dB/oct.
- Limiter with Threshold, Attack, Hold and Release, separate and individually on all output channels
- Input noise gate, programmable with Threshold, Attack and Release
- Store up to 32 user presets in the memory
- Save and load presets in your computer
- Connect to the GUI software via USB or RJ485 daisychained network, with automatic sensing for easy operation and use.
- Front to back heat-controlled ventilation, with removable grilles for service and cleaning of accumulated dust in the filter

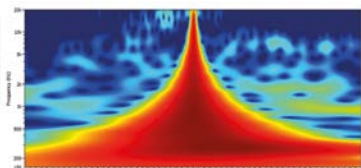

Database with all our speakers, with FIR filter coefficients for perfect phase, amplitude and delay alignment

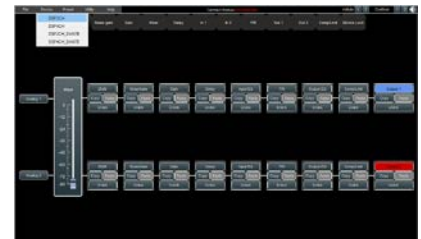

	P21000DSP	P4000DSP	P6000DSP
Channels	2	2	4
Power 8 / 4 / 2 Ω, per channel all channels driven	1000W / 1650W / 2100W	1100W / 1800W / 2000W	1500W / 2300W / NA
Power BTL bridge mode	1 x 3300W @ 8Ω, 1 x 4000W @ 4Ω,	1 x 3600W @ 8 Ω 1 x 4000W @ 8 Ω	2 x 4600W @ 8 Ω, NA in 4 Ω,
FREQUENCY RESPONSE CROSS TALK	20Hz - 20kHz		
MAINS POWER	90-264VAC, 50-60Hz, Power Factor correction		
CONNECTORS	Balanced XLR in/out, Speakon		
DIMENSIONS W x D x H	Width: 19" / depth: 280mm. behind rack, 30 mm. in front of rack, Height 1RU		
WEIGHT	10 kg. net / 11,7kg. shipping	11 kg. net / 12,7 kg. shipping	11 kg. net / 12,7 kg. shipping

2 and 4-Channel installation amplifiers with DSP, 9,5" (half-19")



SPECIFICATIONS

- Width 9,5" / Height 1 RU / Depth 27,5 cm.
- Database with Prophon-speaker presets
- DANTE™ audio over network available (D) version
- DSP with EQ, delay, limiter, crossover
- FIR-filter algorithms.
- 2,5mS fixed latency architecture
- Network with webserver
- Gigabit ethernet switch
- 2 channels and 4 channels
- Wide mains input 90-264VAC
- PFC, Power Factor Correction
- 70V, 100V, 2 ohm, 4 ohm, 8 ohm, 16 ohm.
- Matrix signal distribution
- Power sharing between channels
- Mountable in rack, on wall, under desk, in ceiling
- Green power with programmable on/off
- Fully controllable via 3rd party controls
- Control system for zones
- GUI for handling zones, sources, presets (scenes)
- GUI for any device with a webbrowser in the network
- touch panel for installation
- All Prophon small to medium sized installation speaker in the loudspeaker database, for easy access and aligning of channels.

DESCRIPTION

Compact but yet powerful installation amplifiers for a variety of applications, with advanced DSP with FIR, EQ, delay, limiter, crossover, signal matrix. 2 - 4 channel input and output, 125W-250W-500W power with power-sharing for amplifier channel optimization. The (D) versions offer DANTE™ allowing for distribution of signal in a DANTE™ network. With Network, Gigabit ethernet switch and GUI software for setup, programming and remote control. The series is designed for stand-alone sound systems in small sized installations in commercial audio, classrooms, restaurants, conference rooms, auditorium etc. and for networked medium to large installations in theme parks, churches, sports facilities, work-out facilities, museums, conference centers, schools etc. The amplifiers can be mounted 1-2 in a single 1RU 19" rack, or mounted in ceilings, under desks or on walls with the flange mounting brackets.

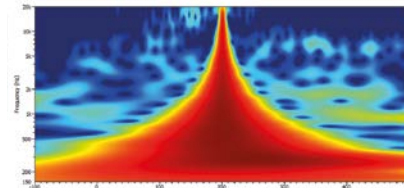

Database with all our speakers, with FIR filter coefficients for perfect phase, amplitude and delay alignment

(D) for dante version	P2160DSP(D)	P4150DSP(D)
Power @ 100V, 70V	1 x 250W	2 x 250W
Power @ 2, 4, 8, 16 Ω	2 x 125W	4 x 150W
Maximum powersharing per channel 100V, 70V, 8Ω, 4Ω	250W	250W
S/N (20Hz-20kHz @8Ω analogue) DANTE™/AES67 2dB greater	>103dB	102dB
Operating voltage	Nominal 100-240 VAC @50-60Hz, Operating voltage 90-264 VAC @ 50/60Hz	
DSP AD converters:	24bit@48kHz, 125dB-A, 0,00x % THD+N, DSP DA converters: 24bit@48k-Hz. 115dB-A, 0,00x THD+N	
	100mS delay per output for time-alignment, Crossover: Butterworth, Linkwitz-Riley, Bessel 6-24dB / oct.	
	EQ: parametric, hi/lo-shelf, band-pass, band-stop, 32 bit floating point, 2,5mS fixed latency architecture, Limiter: RMS voltage, peak limiter,	
Frequency response:	20Hz-20kHz, Gain: 17dB - 47dB (0,1dB increments)	
Input sensitivity:	4dBu (balanced) -10dBV (unbalanced), Max input level: 18dBu / 6,16V, Crosstalk @ 1kHz: -60dB, CMRR: 60dB	
Input impedance:	10kΩ to GND / 20kΩ balanced	

P-SERIES

2-4 Channel amplifiers, with and without DSP



P4350DSP, P2350DSP



P2800, P2350



P4700

INTRODUCTION

The P-series is a series of amplifiers with and without DSP for installation and portable use, all models housed in a 1RU 19" chassis for space-saving rackmounting. With 2 and 4 channel versions designed for versatile use for stage monitors, installations, subwoofers, fullrange speakers etc. With 2x350W, 2x580W, 2x800W 4x350W, 4x580W, 2x800W, 2x1300W, 2x1750W, with some models also being able to supply HI-Z 100V The P-series offers proven and reliable technology, Each amplifier can be bridged for more power allocated to fewer channels for subwoofers etc. 2-channel versions stable in 2 ohm load allows for several speakers to be powered by each channel. P4350DSP with built-in DSP processors.

FEATURES

- 4 models class-D amplifiers
- 2 channel and 4 channel versions
- With DSP and without DSP
- 2x350W, 2x580W, 2x800W 4x350W, 4x580W, 2x800W, 2x1300W, 2x1750W
- Only 1 RU in height allows for tight rackmounting
- Light weight SMPS PDU
- 2-channel models stable in 8, 4, 2 ohm load, 4-channel models stable in 8 and 4 ohm
- Designed for installation and portable use
- 2-channel models bridgable in 8 ohm and 4 ohm, 4-channel models bridgable in 8 ohm
- P4350DSP and P2350DSP with DSP, 15EQ-points on all input and all output channels, HP and LP- filter on all output 6-48dB/oct, Linkwitz-Riley, BUTT, Bess, Limiter, compressor, delay, signal matrix with total freedom in routing
- GUI software for programming and monitoring, copy function on all separate features, or copy all between channels
- Front-panel with display and buttons for navigating in the menusystem and functions, all functions can be accessed from the front panel or GUI

	P2800	P4700	P2350 / P2350DSP	P4350DSP
Power 8 Ω	2x800W	4x350W	2x350W	4x350W
Power 4 Ω	2x1300W	4x580W	2x580W	4x580W
Power 2 Ω	2x1750W	NA	2x800W	NA
Power BTL 8 ohm	1 x 2600W (also 100V)	2 x 1100W	1x1160W (also 100V)	2 x 1160W (also 100V)
Power BTL 4 ohm	1 x 3500W	NA	1x1600W	-
FREQUENCY RESPONSE CROSS TALK	20Hz - 20kHz >75dB			
S/N (20Hz - 20kHz A-Weighted @ 8 ohm)	Typical >-80dB			
DAMPING FACTOR SLEW RATE	> 500 @ 20Hz - 20kHz 50V/us			
THD+N 1/2 Power	0,3% (typical < 0,1%) 0,1% (typical < 0,05%)			
MAINS POWER	90-264VAC, 50-60Hz	230VAC +/- 10%, 50Hz	90-264VAC, 50-60Hz	90-264VAC, 50-60Hz
CONNECTORS	XLR connectors 3-pin balanced input and Speakon output			
DIMENSIONS WxDxH (cm.)	483 x 250 x 45	483 x 355 x 45	483 x 250 x 45	483 x 270 x 45
WEIGHT	5,5 kg. net / 7,5 kg. shipping	5,5 kg. net / 7,5 kg. shipping	5,5 kg. net / 7,5 kg. shipping	5,5 kg. net / 7,5kg. shipping

P-SERIES HP

2-4 Channel High-Power amplifiers, with and without DSP



INTRODUCTION

The P-series HP, is a series of high-power amplifiers without DSP for installation, tour and portable use with external DSP-processors. All models housed in a 1RU 19" chassis for space-saving rackmounting. With 2 and 4 channel versions designed for versatile use for stage monitors, installations, subwoofers, fullrange speakers etc. Ranging from 2x2000W to 2 x 7500W, the HP-series feature massive amounts of high quality capacitors for stable and reliable power, with wide mains 90-260VAC, Powerfactor correction and SMPS (Switched Mode Power Supply) and the latest generation Class-D technology with 90% efficiency, with damping factor of up to 5000 (P10000, P15000) for total cone-control.

FEATURES

- 3 models class-D amplifiers
- 2 channels
- Without DSP
- Only 1 RU in height allows for tight rackmounting
- Light weight SMPS PDU,
- Latest generation Class-D amplifier with 90% efficiency
- Powerfactor correction
- Wide mains input 90-260VAC
- 2-channel models stabile in 8, 4, 2 ohm load,
- Designed for installation and tour use
- Bridgable in 8 ohm and 4 ohm,
- Display with temp, volume and other information P10000 and P15000 (not P4000)
- Protection: soft-start, DC, Infrasonic, VHF, Overheat, Short circuit,
- unique peak limiter
- Damping factor >5000 (P10000 & P15000) for extreme control over current and Voice-coil movement

	P4000	P10000	P15000
Power 8 Ω	2x1100W	2x2000W	2x3500W
Power 4 Ω	2x1800W	2x3500W	2x6500W
Power 2 Ω	2x2000W	2x5000W	2x7500W
Power BTL (bridged) 8 ohm	1 x 3600W	1 x 6800W	1 x 13000W
Power BTL 4 ohm	1 x 4000W	1 x 9600W	11 x 13500W
FREQUENCY RESPONSE CROSS TALK	20Hz - 20kHz >75dB		
S/N (20Hz - 20kHz A-Weighted @ 8 ohm)	>106dB	>110dB	>110dB
DAMPING FACTOR SLEW RATE	>600 @ 20Hz - 200Hz	>5000 @ 20Hz - 200Hz	>5000 @ 20Hz - 200Hz
THD+N	0,5% (typical < 0,1%) 0,1% (typical < 0,05%)		
Slew rate	20 V/μs @ 8 Ω	50 V/μs @ 8 Ω	50 V/μs @ 8 Ω
MAINS POWER	90-264VAC, 50-60Hz		
CONNECTORS	XLR connectors 3-pin balanced input and Neutrik Speakon output		
DIMENSIONS WxDxH (cm.)	483 x 251 x 44	482 x 460 x 44	482 x 460 x 44
WEIGHT	5,7 kg. net 6,9 kg. shipping	12 kg. net 13 kg. shipping	12 kg. net 13 kg. shipping

DSP-SERIES

DSP4800, FIR SYSTEMS-PROCESSORS WITH LOUDSPEAKER DATABASE

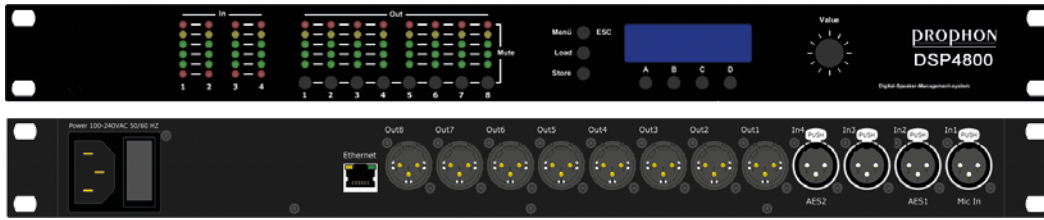

INTRODUCTION DSP4800

The DSP4800 is a powerful systems processor with all prophon speakers stored in the memory for routing to any outputs. Designed for where our systems amplifiers is not an option, such as upgrading an installation with new loudspeakers, where the current amplifiers is of good quality and is to be re-used, simply install the DSP4800 as a systems processor. Another application is for rental companies changing their loudspeakers to Prophon from another brand, but want to keep their existing amplifiers due to cost-efficiency or just because they like them very much, either way, buy a couple of DSP4800 and use as systems DSP loudspeaker processors, and you will have access to all presets and functions required for driving any Prophon system. With 4 analogue inputs and two pairs of AES inputs, (channel 1 input can also be used for microphone input), and 8 outputs, the DSP4800 is a versatile work-horse for fixed installations, tour and portable use, with Wide mains voltage input 95-240VAC, Switched mode power supply.

The processing performances is truly amazing, using SHARK DSP's with 40-bit floating point, 96kHz sampling rate and high-end AD/DA with 120dB SNR and +18dBu Input / Output levels.

All channels are freely routable for convenient systems configuration, where each output can be assigned any of the speakers in our range loaded from the internal loudspeaker database.

FEATURES

- Four analogue inputs, wherein input 1 also can be used as a microphone in with +20dB gain (+48V phantom power available)
- Two AES pairs input for digital signal flow multiplex with analogue input 1 and 4
- Eight analogue outputs
- RJ485 for ethernet
- All Prophon speaker presets are stored in the internal database for easy access and assigning to any output
- Flexible routing
- 15 user IIR EQ on each input channel
- 10 user IIR EQ on each output channel
- 500mS Delay per channel output
- 1000mS delay per channel input
- Compressor and limiter per output channel
- Frequency, gain and Q-value is adjustable individually on each IIR EQ point
- Two crossover on each output (HP/LP)
- Crossover types: Linkwitz-Riley, Butterworth, Bessel
- Crossover slopes from 6dB to 48dB / oct
- FIR with 1024 TAPS in and 512 TAPS out
- 24 custom presets can be stored by user,
- High-End DSP's with 40 bit floating point / 96kHz sampling rate
- High-end AD/DA with 120dB SNR and +18dBu input / output levels
- -100dB THD/N AD
- -104dB THD/N DA
- Ethernet connection 10/100MBit for connecting in network and for connecting computer with the GUI software
- User friendly front-panel menu, with 7 multi function buttons, 1 rotary encoder with puch function,
- Graphical LCD display for clear view and adjustment of all parameters
- Parameters are editable using the front panel and display
- Use a computer with the GUI software for in-depth editing and for managing several devices in a network (router required)
 - Grouping of several channels and units in several layers and depth.
- DANTE / AES67 as option
- Wide mains input 95-240VAC
- Dimensions: 482 x 44 x 210 mm.
- Weight: 2,8kg



DSP-SERIES

DSP SYSTEMS PROCESSORS



DSP480W - DSP processor 4 in / 8 out with WiFi

The DSP480W is the latest version of the DSP480 systems signal processor for installation and portable single ended use, with WiFi for networking.

With four inputs and eight outputs with free signal routing for building and storing systems.

Each input and each output features 9 PEQ, and each input channel also features an additional 31 band GEQ, with 2000mS delay on each input and each output in steps of 21uS, with crossover on all outputs 6-48dB Linkwitz-Riley, Bessel, butterworth. 112dB dynamic range and a 0,002% distortion @ 1kHz, 0dBu,

Compressor/limiter with gatem ratio, attack and release,

The DSP480W is perfect for installing and for portable and tour usage, with wide mains power input 90-240VAC, switched mode power supply

FEATURES

- 4 analogue inputs / 8 analogue outputs
- High performance AD/DA chip and high speed DSP
- 9 PEQ on each input channel and each output channel
- Additional 31 band GEQ on each input and output 1/3 oct.
- Support USB/RS485, WiFi and ethernet
- Input / output delay 0-2000mS in steps of 21uS
- EQ types: PEQ, Low-shelf, High shelf, Phase shelf
- EQ bandwidth: PEQ 0,017 - 4,750 Oct, GEQ 31 band EQ 1/3 oct.
- Crossover on each output 19,7Hz - 21,9kHz, 6 - 48dB slopes
- Crossover types: Butterworth, Bessel and Linkwitz-Riley
- Compressor: Gate -20 - + 20 dBu in steps of 0,5dBu
- Dynamic range 112dB, separation 95dB, Distortion 0,002%
- Wide mains voltage input 90-250VAC
- Weight 3,8kg. Dimensions: 482 x 213 x 45 mm.



DSP24 - DSP processor 2 in / 4 out

Basic digital crossover and DSP-processor with 2 input and 4 output for installation and portable sound. all features needed for a system setup is included, with EQ, delay, limiter, crossover, signal routing etc. perfect for a 2-way stereo system with subwoofers and top speakers. easy to program either using the GUI-software or via the front panel using the buttons and the rotary encoder, with channel-copy for quick setups. DSP24 is a reliable work-horse with wide mains input of 90-250VAC.

FEATURES

- 2 analogue inputs / 4 analogue outputs
- 5 PEQ on each output channel Q 0,4-128
- GUI software, connection via USB
- Output delay 0-7mS in steps of 0,02mS
- Crossover on each output 6 - 48dB slopes
- Crossover types: Butterworth, Bessel and Linkwitz-Riley
- Limiter on all outputs with level, attack, hold, decay
- Dynamic range 112dB, separation 95dB, Distortion 0,002%
- Wide mains voltage input 90-250VAC
- Weight 3,8kg. Dimensions: 482 x 160 x 45 mm.

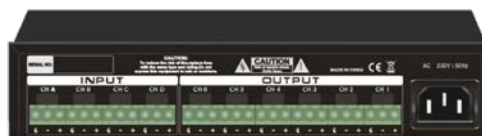

DSP46 - DSP processor 4 in / 6 out 9,5"/1RU

Compact and powerful DSP processor for installation, only 9,5" (half-rack) in width, and 1RU in height, perfect for installations with limited rack-space, The DSP46 is compact, but with a lot of features, with balanced phoenix euroblock connectors for input and output.

The only features accessible from the front panel is the five first presets in the stored memory, accessed by pressing and holding buttons A to E for recalling stored presets, convenient for installations with different usage with different scenes and setups. Inside the DSP you will find an abundance of features, 10 EQ points on all input channels and all output channels, signal routing with total freedom, Input Noise-gate, Delay on all input and all output channels, Crossover on all output channels with HP-filter and LP-filter, individual limiter on all output channels.

FEATURES

- 4 analogue inputs, 6 analogue outputs
- 10 PEQ on each input channel and each output channel
- Support USB/RS485, for GUI software
- Input / output gain
- Input / output delay
- EQ types: PEQ, Low-shelf, High shelf,
- Crossover on each output 6 - 48dB slopes
- Crossover types: Butterworth, Bessel and Linkwitz-Riley
- Compressor: Gate -20 - + 20 dBu in steps of 0,5dBu
- Phoenix / Euroblock connectors
- S/N ratio 99dB, Distortion 0,05% (1kHz, 1Vrms)
- Weight 2,2kg. Dimensions: 214 x 185 x 45 mm. (9,5" / 1RU)

PDU-SERIES

Power Distribution Units for tour and fixed installations

INTRODUCTION PDU-SERIES

We have developed several high-end, reliable PDU's for fixed installations and tour applications, available with and without meters. Using only high-quality components from leading European suppliers ensures stability, reliability and longevity. All PDU's manufactured according to European standards and connectors, not available in all regions and countries.

RCD(RCCB) = Residual Current Device, or, Residual-Current Circuit Breaker, or Ground-fault circuit interrupter, is a device that quickly breaks an electric circuit to prevent serious harm from electric shock, designed to quickly and automatically disconnect a circuit when it detects that the electric current is not balanced between the supply and return conductors of a circuit, the yellow push button is for testing the circuit.

MCB = Miniature Circuit Breaker, A circuit breaker is an automatically operated electrical switch designed to protect an electrical circuit from damage caused by excess current from an overload or short circuit. Its basic function is to interrupt current flow after a fault is detected.

PDU87471

1-phase 230V/16A, 1RU, 19" with on/off switch, with 2m. cable with schuko male for power in, and 8 x Schuko panel out for power-distribution



PDU87473

5-pin, 3-phase 16A CEE connector in on 2m. cable, 3pairs of phase out (L1, L2, L3) for 3-phase distribution, 1RU/19"



PDU16

5-pin, 3x16A CEE connector input in the back 6 x schuko output in the back with 2 x schuko on each group, L1, L2, L3, with LED light for each phase, Frontpanel houses 1 x RCCB with test function and 3 x MCB, one for each phase 3RU, 19"



PDU16M

5-pin, 3x16A CEE connector input in the back 6 x schuko output in the back with 2 x schuko on each group, L1, L2, L3, with LED light for each phase, Frontpanel houses 1 x RCCB with test function and 3 x MCB, one for each phase. Digital high-precision meter with Voltage, current and power monitoring 3RU, 19"



PDU32

5-pin, 32A CEE connector power input on 2m. cable, 2 x CEE, 3-phase 16A output in the back, 6 x schuko output in the back and 1 x schuko output in the front, Frontpanel houses 1 x RCCB with test function and 2x3 x MCB for 2 x output CEE 16A (L1, L2, L3 x 3), and one MCB for each schuko connector output, LED light for each phase 3RU, 19"



PDU32T

5-pin, 32A CEE connector input and 5-pin 32A link output in the front 3 x 3 Neutrik PowerCon True output in the back with 3 connector on each group, L1, L2, L3 Frontpanel houses 3 x MCB, one for each phase (L1, L2, L3) with LED light for indicating power 3RU, 19"



PMA-SERIES

Commercial audio mixer amplifiers and zone-mixer amplifiers for fixed installations



PMA4240D - ZONE MIXER AMPLIFIER 4x240W

The PMA4240D is a zone mixer amplifier with 4 x 240W amplifiers for powering up to 4 individual zones, with built-in media player with MP3-player via USB and SD, and bluetooth, PMA4240 also features 6 source input, where each source can be routed freely to any or all output zones, with separate gain and bas/treble controls, each zone out also features a line out for connecting additional amplifiers or to connect to other products for distribution of signals. all programming, mediaplayer control, settings and routing is made in the color display, with the programming rotary encoder. ht ePMA4240D also have EMC input. The amplifier can power Hi-Z 100V/70V and Lo-Z 4-16 ohm, The PMA4240 is usually enough to power all common areas in a medium sized multi-zone installation, there are external wall panels for zone control, and an announcement mick for adressng zones 1-4 and all call.

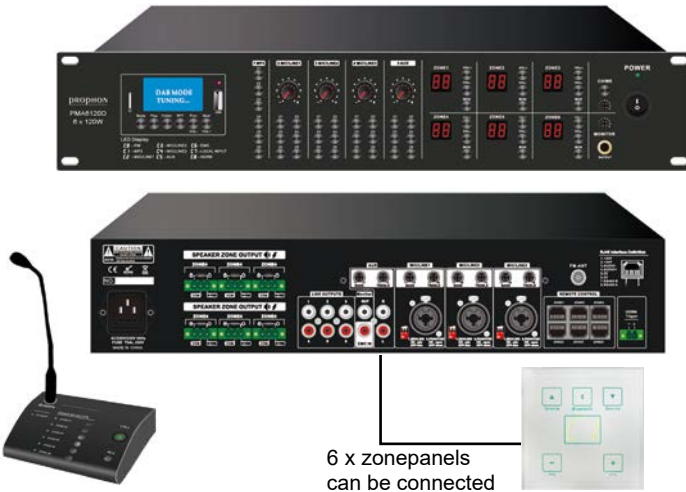

PMA6120D - ZONE MIXER AMPLIFIER 6x120W

The PMA6120D is a zone mixer amplifier with 6 x 120W amplifiers for powering up to 6 individual zones, with built-in media player with MP3-player via USB and SD, and bluetooth, PMA6120D also features 3 Mic/line source input via XLR/Tele combo, and one stereo RCA AUX input, each with individual bass and treble controls, where each source can be routed freely to any or all output zones, with separate gain and bas/treble controls, each zone out also features a line out for connecting additional amplifiers or to connect to other products for distribution of signals. Each input source features output routing buttons for adressng freely to any of the six outputs. The PMA6120D also has EMC input. The amplifier can power Hi-Z 100V and LO-Z 4-16 ohm, The PMA6120D is usually enough to power all common areas in a medium sized multi-zone installation, there are external wall panels for zone control, with source select, volume and local Bluetooth receiver., and an announcement mick for adressng zones 1-6 and all call.

6 x zonepanels
can be connected

PMA350 - MIXER AMPLIFIER 350W

The PMA350 is a mixer amplifier with 350W. distribution via 100V Hi-Z or 4-16ohm Lo-Z. With 3 x balanced mono line/mick in and 2 x unbalanced stereo in for up to 5 sources, with separate volume controls for each source and bas treble for master out. With built-in media-player MP3-player via USB or SD, and bluetooth, the PMA350 is a simple to use mixer amplifier with many features and functions, if used in 100V, 35 speakers set to 10W/100V can be used, or 70 speakers set to 5W/100V, or 17 speakers with 20W/100V, depending on SPL and distribution needed.

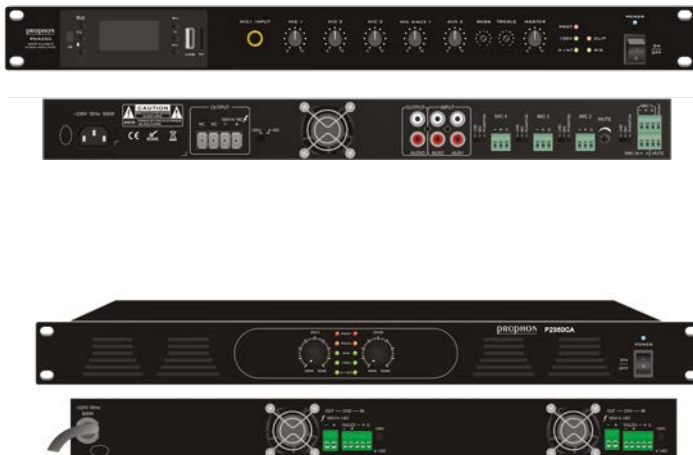

P2350CA - HI-Z 100V / LO-Z 4-16 ohm AMPLIFIER 2 x 350W

2-channel amplifier with class-D technology, 1RU in height, standard 19" rackmount, with 100V HI-Z, and 4-16 ohm LO-Z amplification, for commercial audio installations, 2 x 350W

PM-SERIES

Commercial Audio mixers, zone-mixers and zone matrix-mixers for fixed installations



PM26 - rackmixer for fixed installations

The PMA26 was designed for installations where the system must be easy to operate and use, like in schools, churches, work-out facilities, restaurants, shops, boutiques etc.

The mixer has up to six line input, or two microphone in and four line in, with separate input gain control on all inputs. Mick 1 and 2 has separate volume, bas, treble controls accessible on the front panel for easy and user-friendly functionality.

Line 3, 4, 5 and 6 features a source select switch with combined volume, bas and treble controls, since only one of the four line input can be selected with the source select switch at the same time.

There is left and right balanced XLR master out, with two separate master volume controls,

PMA26 Also features unbalanced stereo RCA rec out.



PM82 - zonemixer for fixed installations

19" Zone mixer pre-amplifier, with 8 input and 2x2 zone outputs

Input 3-6 via balanced XLR can be used as mick in, phantom powered mick on, or Line in. 7-8 line input via unbalanced stereo.

On the front panel, channel 1 features a balanced XLR in and channel 2 features an unbalanced stereo RCA in, for quick-connecting a mick and a sound source such as Phone, MP3-player computer etc. Each input features bass and treble adjustments, gain and volume.

There are Two separately controlable zones out, using four balanced XLR connectors. Additionally there are two unbalanced out for zone 3 and 4, Using the RJ485 enables external control of the audiobus. Usign jumpers housed inside the cabinet,



PM102 - zonemixer for fixed installations

19" Zone mixer pre-amplifier, with 8 input and 2 zone outputs

Channel 1 input is dedicated to the PTT announcement microphone, channel 2 to 10 input features separate gain, with select switch for mick / line / mick with HP-filter, and also a select switch for adreesing to output 1 / output 2 / output 1 & 2.

Input channel 2 features priority select. Input 2-6 is connected in the back with balanced XLR, input 7-10 features both balanced XLR input, and unbalanced stereo RCA input, for connecting both stereo music sources such as MP3-players, BLUetooth players, computers, web-radio, CD-players, Tuners. etc. and mick or other professional ezuipment via the balanced XLR input.

Both master channel output 1 and 2 features independent volume, bas and treble, output connectors are balanced XLR.

Power input can be used with standard 230VAC or 24VDC, for battery backup.



PM28 - rackmixer with mediaplayer

19" rackmixer with built in media players, Bluetooth receiver,

MP3-player via SD-card and USB, 4 x stereo rca unbalanced

line in, 3 x XLR/JACK combo mic / line in with dynamic, phantom

priority select, 3,5" mini jack line input on front-panel for fast

access with phone as mediaplayer, EMC in, separate volume, bas

and treble on all mic in, separate volume, bas and treble on line

in/media player, stereo balanced XLR output, stereo unbalanced

output RCA and JACK



PM42 - mixer/pre-amplifier and mediaplayer, 9,5" / 1RU

Compact stereo rack-mixer for installations, with built-in media-player,

4 x stereo line in unbalanced RCA, Stereo balanced XLR out, stereo

unbalanced RCA out, Mick in, FM-radio, MP3-player with SD-card and

USB, Bluetooth receiver, EMC in, separate volume, bas and treble for

line/player and mick in, only 9,5" wide and 1RU in height.

PROAMP-SERIES

Panels and cases configured for tour, portable and installation



PRO-AMP RACKS

For tour and large format installation we offer our PRO-AMP RACKS. Pre-assembled tour-racks, cases or installation-racks with PDU (Power Distribution Unit) Amprack-connector panel and DSP-amplifiers, mounted and wired for "out-of-the-box" use. We supply several different AMP-RACKS, from small 1-phase 16A, to 3x16A, 32A and 63A. All PDU's features meters, RCD, RCB, with daisychained networking.

We offer a variety of connectors, depending on what is standard in your region, from Neutrik Speakon 4-pol and 8 pole, to multipin connectors, 8, 16 and 19 PIN. All amp-racks are ordered as custom products due to the large variety of applications and needs.



CBU4

Cabinet/case for mounting on any of our 18" or 21" subwoofers, for stacking amplifiers in the system. Rubber shock-mounted rack-frame 4RU/19" for heavy duty "on-the-road" use, with speaker grille facing forwards, and amplifiers and panels facing back, included two lids for safe transportation, M10 or M20 top hat mounted on top, for groundstacking and top-speakers mounted on speaker pole.

AMPRACK PANELS

Our amprack panels for tour, installation and portable use, was designed for comprehensive cabling and connectivity, with all connectors, line, ethernet, speaker and software network connectors easily accessible on the front panel, for mounting in 19" racks with systems-amplifiers, such as the V-series, P-series and D-series



AMPRACK01, supports one and two 4-channel amplifiers and 16A power input in, network, 4 x XLR Neutrik input, 4 channel speaker output via Neutrik NL4MP 1+/-, with additional two 4-pin Neutrik NL4MP speakon output for combined channel 1+2, and 3+4 using 1+/- for channel 1 and 2+/- for channel 2, and 1+/- for channel 3, and 2+/- for channel 4, Option with 4 x input XLR and 4 x through XLR instead of 4 x Neutrik Speakon output 1+/-, 19"/1RU,



AMPRACK02 supports up to 16 channels amplifiers, with 4in / 16out, 2x2 AES in, network primary and secondary (DANTE as option), each 4-channel amplifier output features two NL4MP connectors and one NL8MP connector. supporting up to 16 amplified output channels. option for 8 input instead of 4in x 4 through, 2RU/19"

UB-SERIES, Installation brackets

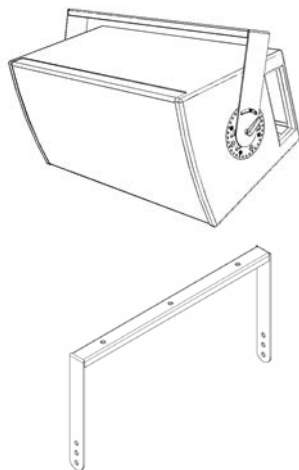

Art. nr.	Description	For speaker(s)
UB5	U-bracket for F5 fullrange speaker	F5
UB6	U-bracket for F6 fullrange speaker	F6
UBF6X	U-bracket for F6X fullrange speaker	F6X
UB8	U-bracket for F8 and MF8 fullrange speakers	F8, MF8
UB10	U-bracket for F10 and MF10 fullrange speakers	F10, MF10
UB12	U-bracket for 12" speakers	F12, F122, Pi121, SUB4
UB15	U-bracket for 15" speakers	F152, SUB5
UBPX28	U-Bracket for PX28	PX28
UBPX210	U-bracket for PX210	PX210
UBPX222	U-bracket for PX222	PX222

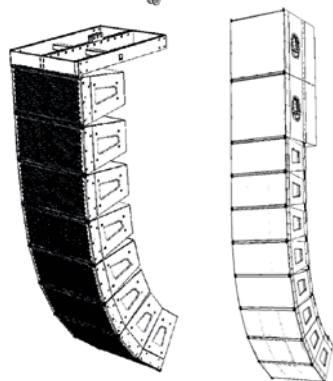
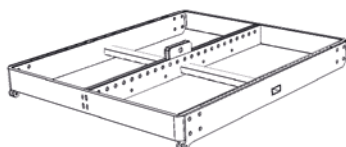

PLAFR-SERIES, Flying frames for line array speakers

Art. nr.	Description	For speaker(s)
PLA26FR	Flying frame for Line array	PLA26P, PLA26A, PLA210A, PLA210P
PLA2611FR	Flying frame for Line array	PLA2611PMK2, PLA2611AMK2, PLA212S, PLA212C
PLA21021FR	Flying frame for line array	PLA21021, PLA215S, PLA1812C
PLA212FR	Flying frame for line array	PLA2124631P, PLA2124631A
CLAMFR	Flying frame for line array	CLAM21041

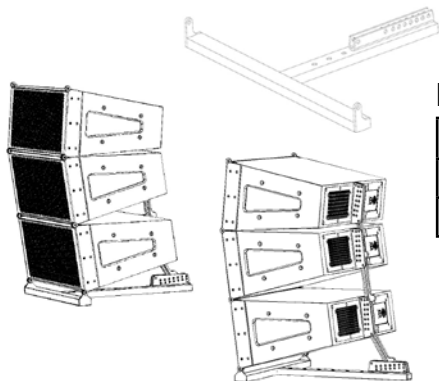

PLAGS-SERIES, groundstack frames for line array speakers

Art. nr.	Description	For speaker(s)
PLA2611GS	groundstack frame	PLA2611PMK2, PLA2611AMK2
PLA21021GS	groundstack frame	PLA21021

BR-SERIES, Multi function brackets

Art. nr.	Description	For speaker(s)
PX28BR	versatile bracket for PX28	PX28, PX28A
PX210BR	versatile bracket for PX210	PX10, PX210A

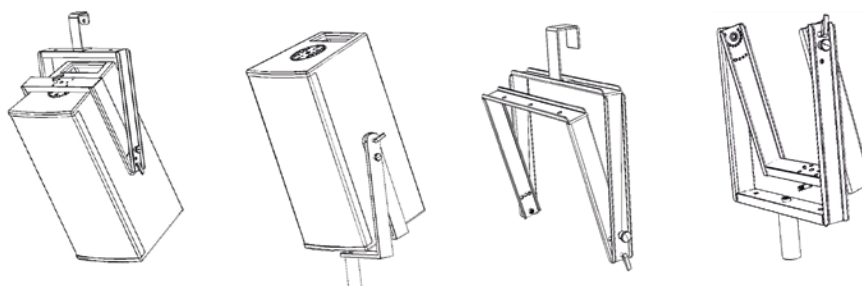



MADE IN SWEDEN SINCE 1985



PROPHON
SOUND SYSTEMS

Prophon Sound Systems pro-audio catalogue 2024, models, data and specifications subject to change without notice
The prophon logo and name are registered trade marks of Prophon Audio & Teknik AB, Stockholm, Sweden, est 1985
www.prophon.com | info@prophon.com | +46 8 92 86 00