

PMA4240

Zone Matrix Mixer Amplifier, 4 x 240W

PROPHON
COMMERCIAL AUDIO



INSTRUCTION MANUAL V1,1



Warning!

- Caution: to avoid electric shock hazard, do not remove cover plate, open, or disassembly in any way, there is no repairable parts inside, contact qualified trained professional for repair and service!
- To avoid fire, damage to product, and/or electrical shock, this equipment cannot be exposed to rain, water or humid environments
- This equipment is intended for professional and commercial use only, not for home use.
- This equipment is capable of (through loudspeakers) producing high SPL (Sound Pressure Levels) that can be damaging for ears and hearing, due to high levels or long time exposure.
There are different standards and regulations in each country, make sure to respect and follow local laws regarding SPL. To be safe, avoid prolonged exposure to volumes exceeding 90 dB, short bursts of high SPL can also be damaging to ears and result in hearing loss and / or tinnitus, please keep volume down.
- Keep away from water, rain, moisture, humid environments.
- Read and understand the manual before installing or using.
- Pay attention to all warnings!
- Use and install the equipment only in the intended manner.
- This equipment may not be tempered with or in any other way changed to be used in a way it was not intended to by the manufacturer
- Clean and wipe only with dry cloth, not with wet cloth.
- The highest ambient temperature is 50° C (122° F)
- Do not restrict or in any way obscure or block the ventilation intake in the front, or outlet in the back
- This equipment uses ventilation cooling systems with fans, when installing make sure there is enough free intake air in front of the amplifier to cool the equipment, and make sure there is enough space for the hot outlet air to dissipate behind the amplifier.
- Do not install heat generating equipment above, below, in front of or at the back of this amplifier.
- This equipment must be earthed, Do not cut earth on the power-in for omitting ground loop, use the ground-lift function.
- Protect all connectors in the back, especially the mains Power input connector
- This equipment needs to be serviced regularly for prolonging the life-span and to make sure the equipment is safe, make sure the mains power is disconnected before service, only qualified personnel may service this equipment.
- If the amplifier in any way act suspiciously disconnect the power-in connector.
- This product is not equipped with an All-Pole power switch, to completely disconnect from the AC power the AC connector must be unplugged from the AC socket.
- Make sure the mains voltage and frequency match the values specified, before connecting the amplifier to the mains.
- Rack mount equipment must have reliable grounding.
- Only use accessories and attachments shipped with the product, or buy original accessories from authorized supplier.
- For personnel safety we recommend that all electrical products are connected to a RCCB (Residual current circuit breaker)
- During lightning storms and / or during time when the amplifier is not used, disconnect the power-in cord.
- This device must be maintained and serviced by qualified personnel only, if the amplifier do not work properly or work faulty only qualified personnel may repair.
- If the product is dropped, or in any other way mishandled it must be verified by qualified service-personnel before use.
- Never place objects containing liquid close to or on top of this device.
- When mounting in a rack, never mount more than four amplifiers, due to heat dissipation issues.
- Avoid switching the on/off switch in quick succession, it can cause the equipment to have a shorter life-span.
- Only replace fuses with same type and with same value, only qualified personnel may change fuses.
- When disposing of this equipment, make sure you comply with the laws within your country,
- Sort and separate plastic and cardboard for a better environment.
- When using in 100V or 70V mode only 80% of the actual power may be used, the extra 20% power is reserved for headroom and loss of impedance due to cable wiring.
(so when using in 100V/70V mode the amplifier can only be loaded with 4 x 192W)

The PROPHON PMA4240 was designed as a commercial audio product, for public address purpose. With over 30 years of experience in public address commercial audio installations, the PMA4240 was developed after extensive research to satisfy a demand in a multi-purpose machine that can manage most small to medium sized installation in restaurants, schools, stores, work-out facilities, bars and lounges, conference centres etc.

It can be used as a multi-zone mixer amplifier, with the same or different sound sources playing in one, several or all output zones. With five separate input channels the PMA4240 can host external CD-players, tuners, I-pads, I-phones and Android devices, computer, Bluetooth unit etc. and up to 3 microphones (both condenser and dynamic)

The PMA4240 hosts an abundance of features such as:

- 4 zones out with 4 x 240W amplifier (4-16 ohm, 70V, 100V)
- All 4 zone output features an additional signal line output for connecting external amplifiers.
- 5 input channels with separate input gain on the back panel for adjusting the input signal gain structure
2 x stereo RCA, 3 x XLR/TELE combo connector with mic/line select switch and phantom switch
- MP3 player with SD and USB input
- Each input channel features gain, bass, treble, mute and output address
(1 - 4 output, where one, several or all output channels can be addressed)
- One priority input for overriding other input channels (equal to EMC input)
- RS232 serial control port for third party system communication
- Monitor output (1W/8ohm) for listening in on each output channel, (selectable 1-4)
- RJ45 connector for using the 4-zone remote table-goseneck microphone PTM412
- Tel. input for telephone integration
- Several levels of priority, 1) MIC1, 2) Tel. 3) Remote Mic
If "priority" is short circuited, then the priority order is: 1) Remote mic 2) Tel. 3) MIC1

The built-in 4 channel amplifiers features both low impedance 4-16 ohm output, and high impedance constant voltage output for 70V or 100V lines, only one (8ohm/70V/100V) can be used for each channel, but the four channels do not need to use the same output stage, one channel can use 4-16 ohm speakers, one can use 70V speaker line, and one can use 100V speaker line. when using in 70V and 100V mode, only 80% of the power may be used, (4 x 192W) since there needs to be a 20% headroom for greater load due to long cable installations.

Setup suggestions

Work-out facility

The PMA4240 is the perfect choice for running a sound system in a work out facilities, handling environment sound, locker-room sound and café, with separate volume controls for each zone, and with the possibility to play the same source in all zones, or different sources in each zone.

School

In a school, each output zone can handle one separate floor, for addressable zones, where the mic can be used for announcements, for larger facilities just add external amplifiers to expand the system

Restaurant

for background music, with separate volume control in all zones, use two zones for restaurant, one zone for outdoor lounge and one zone for closet, toilets and restrooms.

Announcements can be made to all zones from the PTM412 microphone,

Store

Mainly for medium sized to large stores (for smaller stores with only one zone we suggest our mixer amplifier PMA240 with 1x240W) with 4 x 240W a medium sized store can easily be covered, with the possibility to have different music in different areas (like in a grocery store, where you want to stream sounds recorded by the ocean where you sell fish and seafood, sound recorded on a farm where you sell meat and dairy, and maybe laid-back background music in the rest of the store. Or maybe you run a clothing store, where you want to have one music style in the fitting rooms, and one music style in the rest of the store, with different zones where the music is played on different volumes depending on where in the store you are. with the announcement mic you can announce to all zones.

Functions of front panel

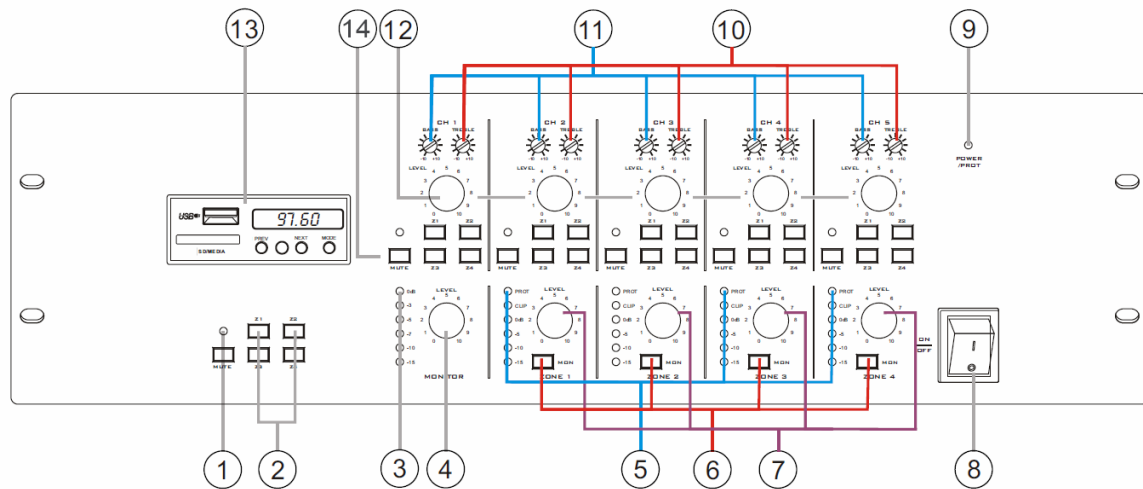

- | | |
|--------------------------------------|---|
| 1) Mute button indicator, tuner/MP3 | 9) Power on indicator |
| 2) Output channel selector tuner/MP3 | 10) Input 1-5 channel treble control |
| 3) Monitor level indicator | 11) Input 1-5 channel bass control |
| 4) Monitor volume control | 12) Volume control of channel 1-5 input |
| 5) 1-4 zone output level indicator | 13) MP3 player with USB and SD slot |
| 6) 1-4 zone output monitor select | 14) Mute input channels 1-5 |
| 7) 1-4 zone output volume control | |
| 8) ON/OFF power switch | |

Functions of back panel

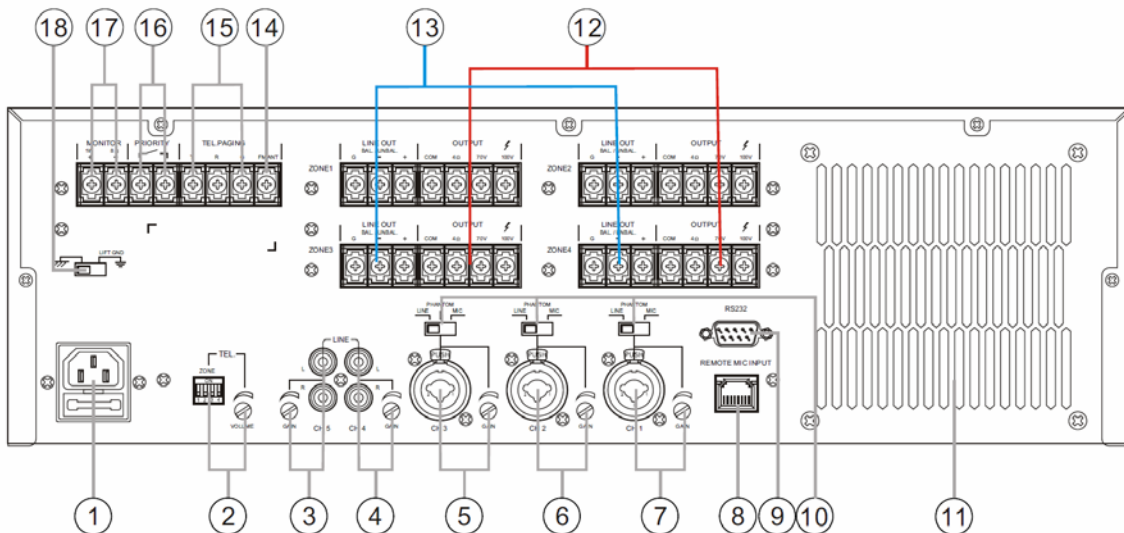

- | | |
|---|---|
| 1) AC power input socket | 10) Line/phantom/mic select, input 1-3 |
| 2) Tel. dipswitch and volume control | 11) Vent. outlet |
| 3) Channel 5 line signal input and gain control | 12) Amplifier output 1-4, COM = neutral (-) |
| 4) Channel 4 line signal input and gain control | 13) Signal output 1-4 balanced/unbalanced |
| 5) Channel 3 line/mic signal input and gain control | 14) Radio antenna input |
| 6) Channel 2 line/mic signal input and gain control | 15) Tel. input signal |
| 7) Channel 1 line/mic signal input and gain control | 16) Priority short circuit |
| 8) RJ485 remote zone mick input (PTM412) | 17) Monitor output (1W amplifier 8 ohm) |
| 9) RS232 port for third party integration | 18) Ground lift |

Channel 1 - 5 line signal Input functions

- 1) Bass, for adjusting the bass boost @ 100Hz
- 2) Treble, for adjusting the treble boost @ 10kHz
- 3) Volume adjustment on input signal
- 4) Mute channel
- 5) Select distribution of signal to output 1 - 4

Channel 1 - 4 amplifier output functions

- 6) Volume control of output channel
- 7) Select button for addressing to monitor listening
- 8) Level status indicators on channel output

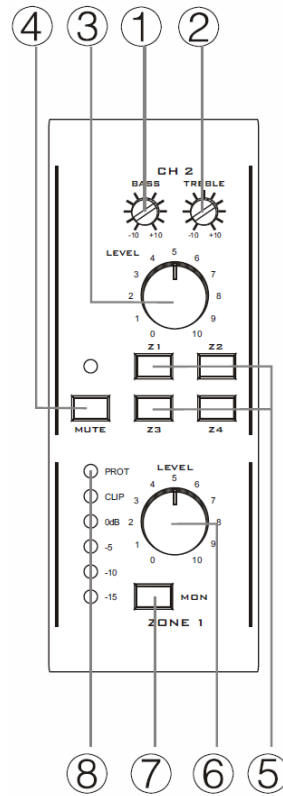

PRIORITY (OVERRIDE) FEATURES

Short Circuit for changing priority order



There are several levels of priority

- 1) MIC1
- 2) Tel.
- 3) Remote mic in

To change the order of priority, short circuit the "PRIORITY" terminals

- 1) Remote mic
- 2) Tel.
- 3) MIC1

CHANNEL 1-3 INPUT FEATURES

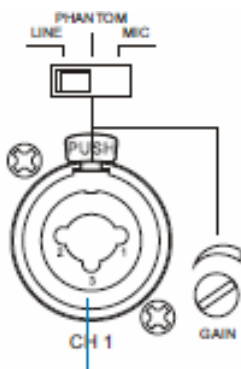

The combo XLR/TELE input connector offers three different input choices, selected with a select switch, the gain is used for adjusting and balancing the gain structure of the input equipment.

"LINE"

For using as audio signal line input with CD-players, Tuners, MP3-players, Computer, phones and other audio equipment

"PHANTOM"

For using condenser microphones, feeding 48V powersupply.

"MIC"

For using standard dynamic microphones

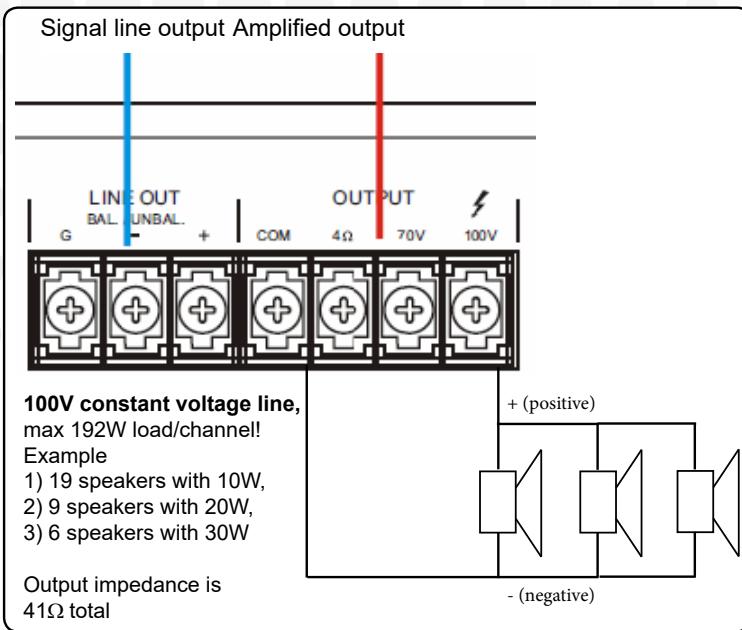
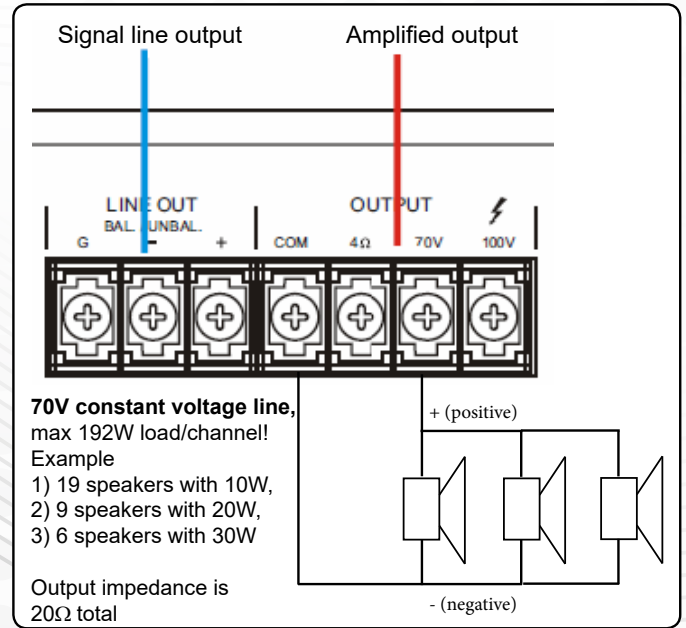
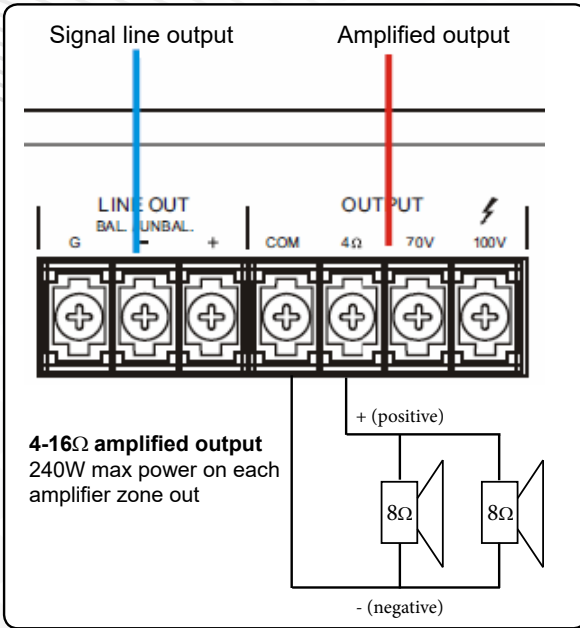

Connection guide

Only use one of the output stages on each output channels, 4-16Ω or 70V or 100V, it is not possible to use several outputs at the same time on the same channel

COM refers to negative (-) on the speaker
4Ω refers to positive (+) on low impedance speakers
70V refers to positive (+) on 70V line speakers
100V refers to positive (+) on 100V line speakers

Do not connect 70V speakers on the 100V output
Do not connect 8 ohm speakers on 70V or 100V output
Do not connect 100V speakers on the 4-16 ohm output
Do not connect 70V speakers on the 4-16 ohm output

Signal Line out

Signal line output can be used to connect external amplifier, for more powerful systems, or for connecting more speakers to the system, each Line out corresponds to the zone output volume on that channel.

70V / 100V connection

It is possible to connect 100V speakers on the 70V line for half effect to be able to use double the amount of speakers on the same amplifier, with half the effect on each speaker. **(DO NOT CONNECT 70V SPEAKERS ON 100V LINE!)** example: if you use 30 pcs. of 10W, 100V speakers, it will add up to 300W, overloading the 192W amplifier when using on the 100V line out, but if you connect the 30 pcs. of 100V / 10W speakers on the 70V line output, each speaker will only "use" 5W, instead of 10W, thus enabling for more speakers to be used, since 30 speakers using 5W each is 150W

100V line on 100W amplifier
with 3 psc. of 100V speakers with
30W tap each = 90W consumption

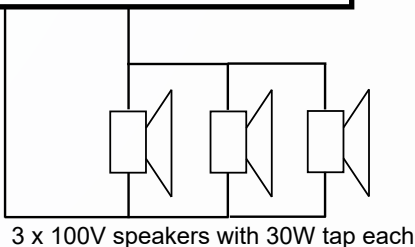

70V line on 100W amplifier
with 6 psc. of 100V speakers with
30W tap each = 90W consumption

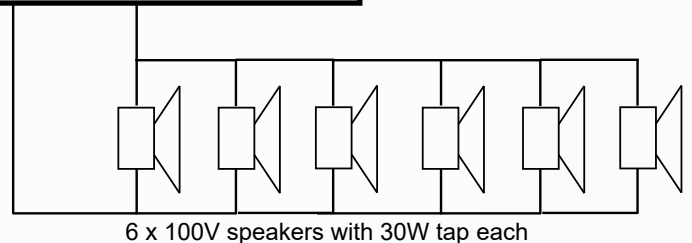

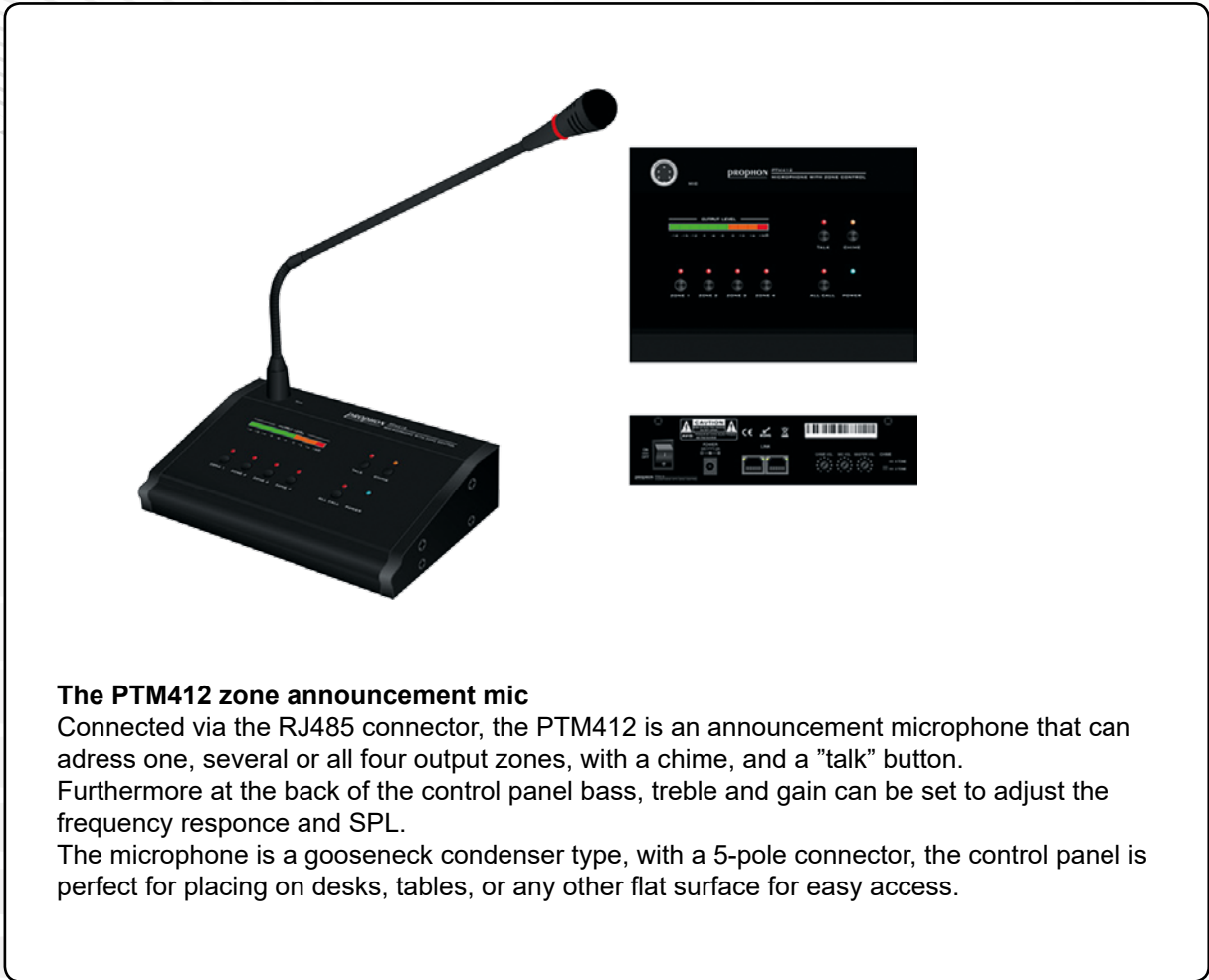

The PTM412 zone announcement mic

Connected via the RJ485 connector, the PTM412 is an announcement microphone that can address one, several or all four output zones, with a chime, and a "talk" button.

Furthermore at the back of the control panel bass, treble and gain can be set to adjust the frequency response and SPL.

The microphone is a gooseneck condenser type, with a 5-pole connector, the control panel is perfect for placing on desks, tables, or any other flat surface for easy access.

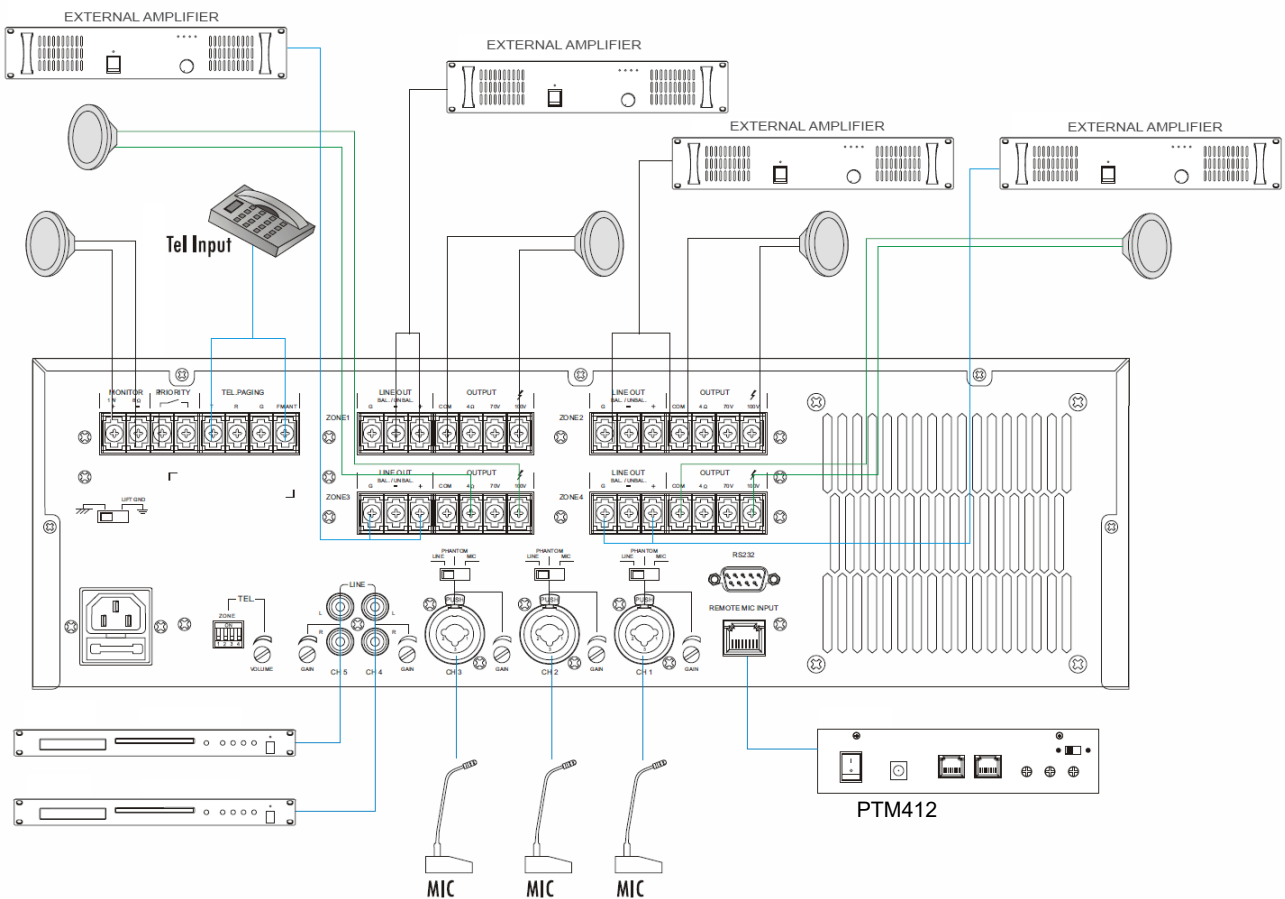

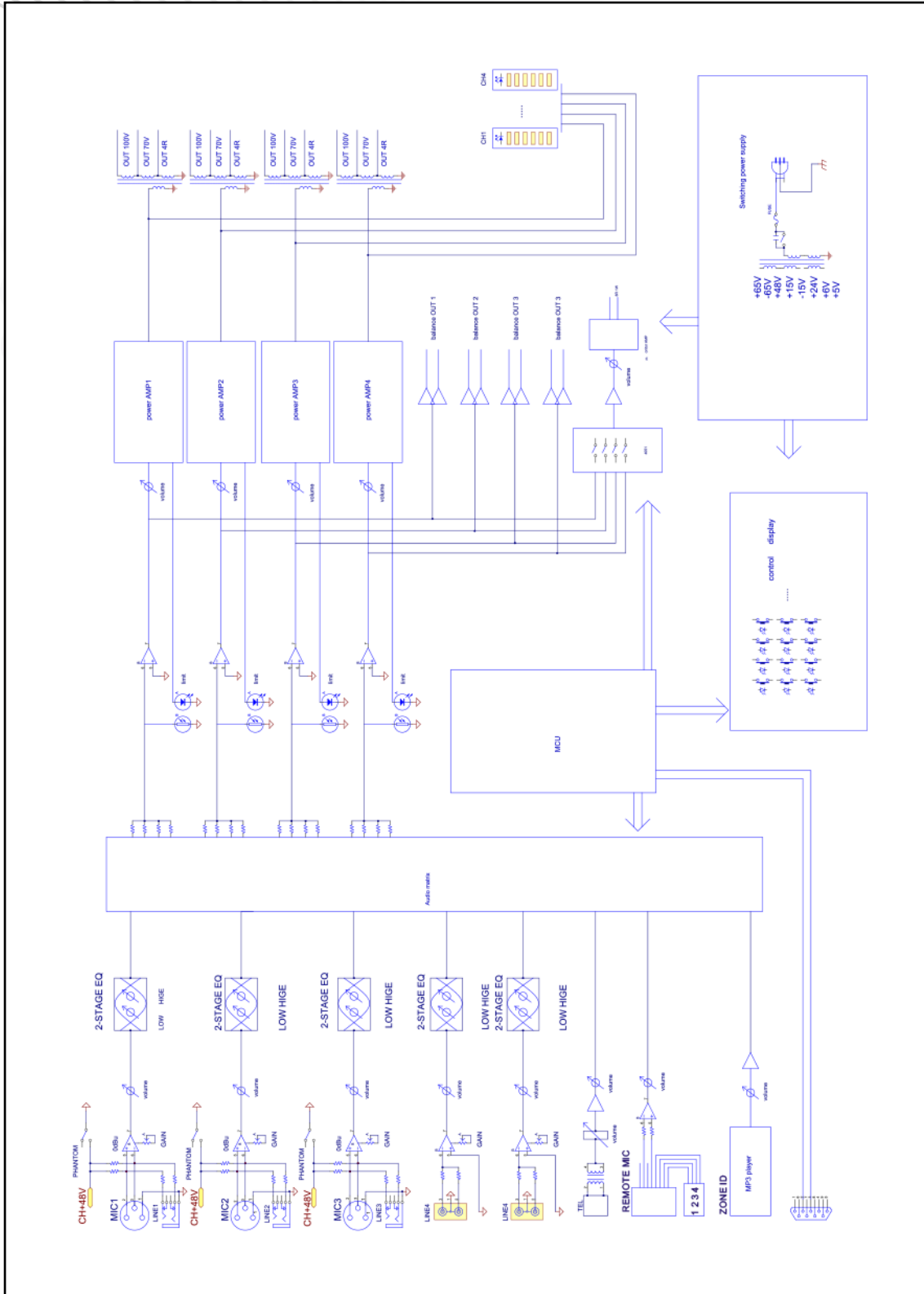

MODEL	PMA4240
MAX POWER OUTPUT 4-16 ohm LOAD	4 x 240W
MAX POWER OUTPUT 70V/100V LOAD	4 x 192W
MONITOR OUTPUT	1W/8 Ω
INPUT SENSITIVITY & IMPEDANCE	CH1-3: MIC +/- 2.5mV/600 Ω Phantom: +/- 2.5mV LINE: ~175mV/10k Ω balanced input CH5-6: 350mV/10k Ω balanced input TEL: 350mV/10k Ω REMOTE MIC: +/-387mV/10k Ω BASS: +/-10dB@100Hz TREBLE: +/-10dB@10kHz
EQ adjustments	\geq 65dB
SNR	1V/600 Ω (balanced output)
LINE 1-4 OUTPUT LEVEL	Support MP3 format (max 32GB capacity)
MP3	FAT16, FAT32, does not support folders
SD FILE SYSTEM	\leq 1%
THD	1500W
POWER CONSUMPTION	230V / 50Hz
VOLTAGE	H132 x W484 x D440
DIMENSIONS	22kg.
NET WEIGHT	24kg.
SHIPPING WEIGHT	