

PROPHON

SOUND SYSTEMS

TRUST YOUR EARS!

**NEW
PRODUCTS
2018**



MADE IN SWEDEN
SINCE 1985

F6X COMPACT COAXIAL FULLRANGE SPEAKER



PRESENTATION

- ▶ Very compact and powerful fullrange speaker
- ▶ 6,5" / 1" neodymium coax
- ▶ Controlled 70° conical dispersion pattern
- ▶ 123 dB Max SPL
- ▶ 300W cont. power handling
- ▶ 8 ohm input with dedicated passive crossover network
- ▶ Available with speakon connectors for tour and portable use
- ▶ Available with Phoenix connectors for installing
- ▶ Smart quick-set hardware for adjusting dispersion angle 0° - 360°
- ▶ Bracket for installing or for use on speaker stand, microphone stand and wall mount.
- ▶ The F6X can be used as a stage monitor where the floor-angle can be adjusted with the bracket

DESIGNED FOR

- The rental and event industry
- Installations in theatres, conference, restaurants and bars, lounges and hotels
- Presentations, recorded music, live performance, speech
- Front-fill
- In-fill
- Delay speaker
- Discreet and architectural installations
- Monitoring in ensembles and large filharmonic concerts mounted on microphone stands
- Stage monitor on small stages

AVAILABLE ACCESSORIES

- 19" systems DSP-amplifier with presets and FIR filters
- Soft bag housing four psc. of F6X speakers and cables, for portable use, event and tour
- Quick clamp for fastening on truss, stands etc.
- Wall-mount brackets for installations
- Microphone stand for using as nearfield monitor.
- Installation hardwares
- Compact Subwoofer for external Low frequency response

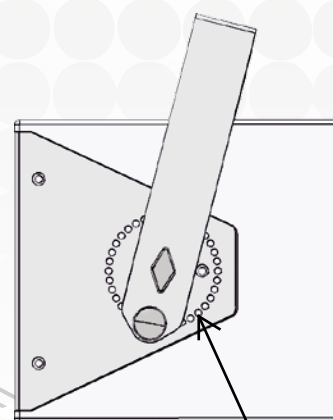

Each hole represents 5° using the quick-release spring for fast and accurate aiming.

HX-SERIES

3-WAY HORNLOADED POINT-SOURCE SPEAKERS



PRESENTATION

- ▶ Horn-loaded design with controlled dispersion pattern
- ▶ Long-throw
- ▶ Powerful 3-way fullrange speakers
- ▶ Two models:
 - HX10:** 2x10"/8"-horn/1"-horn, 2000W cont., 109dB sensitivity, 142dB cont SPL (145dB peak)
 - HX8:** 2x8"/6,5"-horn/1"-horn, 1800W cont. 106dB sensitivity, 139dB cont. SPL (142dB peak)
- ▶ C.C.C. (*Common Compression Chamber*) low frequency emission technology.
- ▶ Available in two versions:
 - Passive:** 8 ohm bi-amplified with Neutrik Speakon NL4MP
 - Active:** Self-powered with 1500W + 400W + 200W class-D amplifier and DSP with four presets
- ▶ Very high sensitivity, and low distortion levels
- ▶ Designed to be used with the B1812HPC and the B318HPC cardioid subwoofers.
- ▶ Can be used as groundstacked, flown or on speaker stand
- ▶ Designed for high power live performance and installations in large venues and nightclubs
- ▶ Full frequency response down to 55 Hz

DESIGNED FOR

- The rental and event industry
- Installations in live performance stages,
- Installations in nightclubs
- Installation in venues, theatres and auditoriums
- Installation in sports arenas
- Bands and DJ's
- High power portable PA-system
- PA-companies

AVAILABLE ACCESSORIES

- 4x5200W and 4x1500W, 19" systems DSP-amplifier with presets and FIR-filters
- Case for tour and rental, housing two pcs in each case.
- Hardwares for rigging, flying, top-hat mounting and stacking
- Installation hardwares

PLA621

COMPACT LINE ARRAY MODULE



PRESENTATION

- ▶ Compact 2-way line array module
- ▶ 1 x 6,5" neodymium woofer
- ▶ 2 x 0,75" drivers mounted on waveguide and horn
- ▶ 123 dB Max SPL
- ▶ 400W cont. power handling
- ▶ Unique metal hardware construction with integrated line array coupling
- ▶ Kick-out connection hardware with kick-release sprints
- ▶ H100 x V15 dispersion controlled pattern
- ▶ Smart quick-release rigging hardware
- ▶ All array-hardware integrated in the inner metal construction and grille.

DESIGNED FOR

- The rental and event industry
- Installations in theatres, conference centers, live performance stages, churches, auditorium, nightclubs, sportsfacilities.
- Front-fill
- Small delay and sidefill system in larger venues and live performance events.
- Full scale compact line array for recorded music, live performance and speech.
- Available in any RAL colour upon request for discrete and architectural installations

AVAILABLE ACCESSORIES

- 19" systems DSP-amplifier with presets and FIR filter
- Case for two and four modules
- Wall-mount brackets for installations
- Installation hardwares and flywares
- Ground-stack hardware for stacking on subwoofers
- Bumper frame for flying line array
- Compact 2x12" Subwoofer for extra Low frequency response
- Active 2x12" subwoofer drives subwoofer and up to eight PLA621 with 1500W + 2 x 750W
- Subwoofer for flying in array or ground-stacking

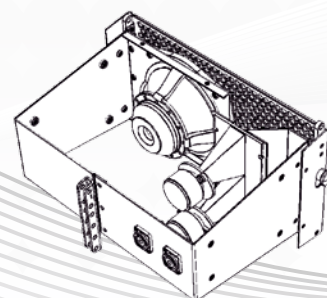

Unique and innovative design with inner metal frame, featuring integrated hardware, connectors, passive crossover, front-grille and quick rigging array sprints.

B18HPC CARDIOID SUBWOOFER



PRESENTATION

- ▶ HIGH POWER CARDIOID SUBWOOFER
- ▶ 1 x 18" neodymium woofer front-loaded in tuned vented cabinet
- ▶ 1 x 12" neodymium woofer loaded in tuned vented cabinet in the back for cardioid pattern
- ▶ Advanced algorithms and acoustic design allows for very accurate cardioid response
- ▶ Available in active self-powered version, and passive bi-amplified versions
- ▶ Active version features 2 x 1500W class-D amplifiers and on-board DSP with 4 presets
- ▶ 4400W total cont. power handling
- ▶ Very high max SPL capabilities of 142 dB peak (139dB cont.)
- ▶ 103 dB sensitivity 1W/1m.
- ▶ Compact size for a cardioid subwoofer of only W500 x H720 x D915 mm.
- ▶ Designed for Tour, PA, portable use and installation
- ▶ Cardioid pattern with controlled dispersion down to 40 Hz reduces unwanted LF on stage, and also cancels out up to 18dB behind the subwoofers
- ▶ In combination with the HX-series 3-way hornloaded point-source speakers the B18HPC is the perfect choice for high power medium sized live performance

DESIGNED FOR

- The rental and event industry
- Portable PA system with the HX-series horn-loaded three-way point source speakers
- High power installations in live performance stages, theatre, clubs and venues
- Stacked and arrayed with Line array systems

AVAILABLE ACCESSORIES

- 19" systems DSP-amplifier 4 x 5200W, with presets for passive use and for installation
- Case
- Soft cover
- Castor plates and cover plates

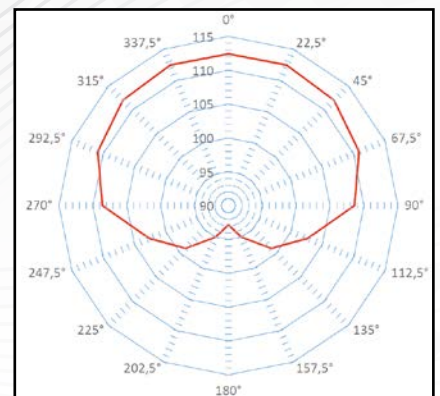

Controlled cardioid dispersion pattern

MF-SERIES mkII

Multi Function fullrange speakers (New versions)



PRESENTATION

- ▶ Next generation MF-series speakers, with new design, improved frequency response, Higher power handling, better phase coherency with new presets and FIR-filters
- ▶ Two models available:
 - MF8:** 8"/1" coax
 - MF10:** 10"/1"-horn
- ▶ Lightweight Neodymium components
- ▶ Available in active and passive versions
- ▶ Passive versions with dedicated advanced passive crossover network 8 ohm, Speakon NL4MP input
- ▶ Active versions with new 600W RMS Class-D amplifiers, PFC, Universal power, AES input, 4 presets,
- ▶ Designed for rental, event and live performance
- ▶ Installation bracket and installation hardwares available for fixed installations
- ▶ Can be used as fullrange "stand-alone", stage monitor, frontfill, delay, top in system with subwoofers
- ▶ Discrete handles that is hidden when using as stage monitor

DESIGNED FOR

- The rental and event industry
- Installations in theatres, conference, restaurants and bars, lounges and hotels
- Presentations, recorded music, live performance, speech
- Front-fill
- In-fill
- Delay speaker
- Discrete and architectural installations
- stage monitor
- Fullrange speaker
- Top in PA-system with subwoofers

AVAILABLE ACCESSORIES

- 19" systems DSP-amplifier with presets
- Soft bag for portable use, event and tour
- Quick clamp for fastening on truss, stands etc.
- Wall-mount brackets for installations
- Installation bracket
- Installation hardwares



MF8 with the adjustable installation bracket UB8

CXL-SERIES mkII

Coaxial Multi Purpose Speakers (new versions)



PRESENTATION

- ▶ Next generation CX-series speakers, with new design, improved frequency response, Higher power handling, better phase coherency with new presets and FIR-filters
- ▶ Two models available:
 - CXL122MP:** 12"/2" coax
 - CXL152MP:** 15"/2"-coax
- ▶ Lightweight Neodymium components
- ▶ Coaxial design for optimal point-source dispersion
- ▶ 80° conical dispersion pattern
- ▶ Available in active and passive versions
- ▶ Passive versions with dedicated advanced passive crossover network 8 ohm, Speakon NL4MP input
- ▶ Active versions with new 600W RMS Class-D amplifiers, PFC, Universal power, AES input, 4 presets,
- ▶ Designed for rental, event and live performance
- ▶ Installation bracket and installation hardware available for fixed installations
- ▶ Can be used as fullrange "stand-alone", stage monitor, delay, top in system with subwoofers
- ▶ Top hat for speaker stand mounting discreetly hidden in one of the handles

DESIGNED FOR

- The rental and event industry
- Installations in theatres, conference, restaurants and bars, lounges and hotels
- Presentations, recorded music, live performance, speech
- Delay speaker
- Installations
- Stage monitor
- Fullrange speaker
- Top in PA-system with subwoofers

AVAILABLE ACCESSORIES

- 19" systems DSP-amplifier with presets and FIR-filters
- Soft bag for portable use, event and tour
- Quick clamp for fastening on truss, stands etc.
- Wall-mount brackets for installations
- Installation bracket
- Installation hardware



CXL122MP with the B18HPA active subwoofer, in an active sound system, where the B18HPA supplies the CXL122MP with 1000W DSP-processed power.

PROPHON

SOUND SYSTEMS



MADE IN SWEDEN
SINCE 1985

Prophon Sound Systems and the Prophon logo are registered trademarks
Manufactured in Täby, Stockholm, Sweden by Prophon Audio & Teknik AB since 1985
Website: www.prophon.com | Mail: info@prophon.com | Tel: +46 8 92 86 00